



## **OPERATIONS & MAINTENANCE MANUAL**

---

Metalpad EX Fire Rated Pedestals

Date 01/03/2023



## PRODUCT DESCRIPTION

### Class A1 Metalpad EX Fire Rated Pedestals

**Non-combustible, fully adjustable, Class A pedestal specially designed for suspended decking and paving systems on exterior high-rise balconies, terraces and flat roofs.**

26 to 675mm in height –Mild steel pedestals with Zintec 200 exterior protective coating for long-term exterior applications.

Zero plastic content. Zero rubber content.

Rated Class A according to BS EN 13501-1:2018 and EC Decision 94/61 1/EC.

Standard weight tolerance per unit = 500kg.

Steel pedestals with designed to hold both paving positioning lugs and be fixed to Wallbarn Aluminium Profiled Rails / Bearers for decking and terrace raft substructure layers.

They are ideal to support Class A decking and paving systems.

They are covered in Zintec 200 coating, which offers outstanding cathodic corrosion protection and staves off white rust formation. Zintec 200 also demonstrates exceptional performance in Neutral Salt Spray Testing (NSST) as well as in Cyclic Corrosion Testing (CCT).

Accurate levelling of the floor surface is possible with millimetre precision by twisting the threaded stem to adjust the height. The height can be adjusted even with the paving slab or rail / decking system in place, simply turn the stem.

The headpiece is 95mm diameter. The circular baseplate is 100mm diameter and optimal spreader plates for additional weight distribution.

For paving applications a positioning lug made from anodized aluminium is inserted into a hole in the centre of the headpiece.

For decking application specially designed rails from Wallbarn are fixed by hand to the tops of the pedestals using a wing nut & both fixing.

## PHYSICAL AND CHEMICAL PROPERTIES

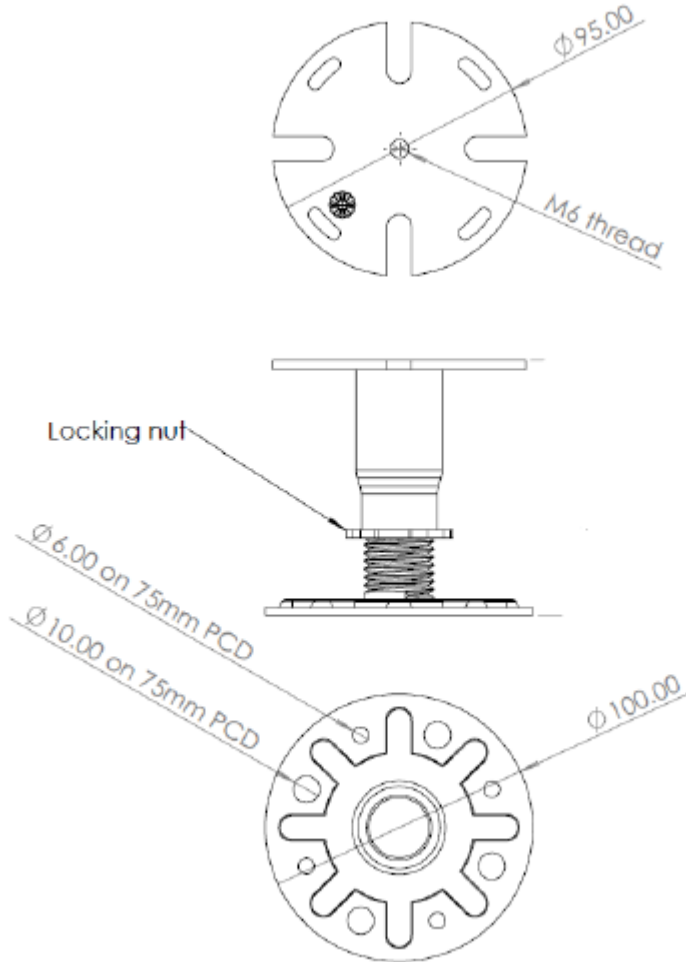

<b>Material</b>	Mild Steel Sheet	EN 10152
<b>Pedestal coating</b>	Zintec 200 corrosion protection coating	
<b>Threaded Stem</b>	Mild Steel class 4:8	
<b>Fire Classification</b>	Class A1	EC Decision 96/603/EC
		BS EN 13501-1:2018
<b>Building Standards Compliance</b>	Approved Document B (amended)	2022
	British Standard (balcony construction)	BS 8579
<b>Use / Purpose</b>	Suspended decking and paving projects	

<b>Height Range</b>	SP-MET-EX-026-Z	Class A MetalPad - EX (flat head) 26-35mm
	SP-MET-EX-030-Z	Class A MetalPad - EX (flat head) 30-40mm
	SP-MET-EX-040-Z	Class A MetalPad - EX (flat head) 40-50mm
	SP-MET-EX-050-Z	Class A MetalPad - EX (flat head) 50-70mm
	SP-MET-EX-060-Z	Class A MetalPad - EX (flat head) 60-90mm
	SP-MET-EX-075-Z	Class A MetalPad - EX (flat head) 75-115mm
	SP-MET-EX-090-Z	Class A MetalPad - EX (flat head) 90-140mm
	SP-MET-EX-110-Z	Class A MetalPad - EX (flat head) 110-185mm
	SP-MET-EX-135-Z	Class A MetalPad - EX (flat head) 135-210mm
	SP-MET-EX-150-Z	Class A MetalPad - EX (flat head) 150-225mm
	SP-MET-EX-185-Z	Class A MetalPad - EX (flat head) 185-260mm
	SP-MET-EX-200-Z	Class A MetalPad - EX (flat head) 200-275mm
	SP-MET-EX-235-Z	Class A MetalPad - EX (flat head) 235-310mm
	SP-MET-EX-250-Z	Class A MetalPad - EX (flat head) 250-325mm
	SP-MET-EX-300-Z	Class A MetalPad - EX (flat head) 300-375mm
	SP-MET-EX-350-Z	Class A MetalPad - EX (flat head) 350-425mm
	SP-MET-EX-400-Z	Class A MetalPad - EX (flat head) 400-475mm
	SP-MET-EX-450-Z	Class A MetalPad - EX (flat head) 450-525mm
	SP-MET-EX-500-Z	Class A MetalPad - EX (flat head) 500-575mm
	SP-MET-EX-550-Z	Class A MetalPad - EX (flat head) 550-625mm
SP-MET-EX-600-Z	Class A MetalPad - EX (flat head) 600-675mm	
<b>Accessories</b>	SP-MET-EX-BASE-Z	Class A MetalPad - EX Spreader Baseplate Ø 185mm
	SP-MET-EX-BOLT-HAM-Z	Hammerhead Bolt/Screw for peds & rails
	SP-MET-EX-HEAD-CRU-Z	Class A MetalPad - EX Lug Head Crucifix
	SP-MET-EX-HEAD-EDGE-PLATE-Z	Class A MetalPad - EX Paving Starter / End Plate
	SP-MET-EX-HEAD-PLATE-Z	Class A MetalPad - EX Paving Lug Headpiece Plate
	SP-MET-EX-HEAD-SL-Z	Class A MetalPad - EX Self Levelling Headpiece
	SP-MET-EX-SCREW-1-Z	Class A MetalPad Ex Paving Lug Headplate Screw
	SP-MET-EX-SCREW-RAIL-BL-Z	Class A MetalPad - Ex Screw for Rail Black
	SP-MET-EX-START-CLIP-Z	Class A MetalPad - EX Starter Fixing Clip
	SP-MET-EX-BASE-Z	Class A MetalPad - EX Spreader Baseplate Ø 185mm
<b>Headpiece</b>	95mm diameter with central hole 6mm diameter 4 x connection slots 10mm x 22mm	
<b>Base Plate</b>	100mm diameter Circular Base plate 4 x drilled drainage holes 10mm diameter 4 x drilled fixing holes 6mm diameter	
<b>Lug Interface</b>	For use with Wallbarn Aluminium Profiled Rail For use with paving positioning lug made from anodized aluminium	
<b>Weight Tolerance</b>	500kg per pedestal – normal load	

<b>Durability</b>	MetalPad EX is manufactured for long-term performance and resistance to corrosion, exposure to elements and to UV rays
<b>Warranty</b>	Limited warranty 15 years
	Life span 50 years
<b>Toxicity</b>	These products are not classified as toxic

## PRODUCT LITERATURE

Included as Appendix A

## FIRE TESTING & CLASSIFICATION

Class A1 – as per EU COMMISSION DECISION of 4 October 1996 establishing the list of products belonging to Classes A 'No contribution to fire' provided for in Decision 94/61 1/EC implementing Article 20 of Council

Directive 89/106/EEC on construction products

## PRODUCT INSTALLATION

To be used on predominantly flat decks. Pedestals to be placed onto the structural decks, sufficiently strong to tolerate the weight of the system. Care should be taken to ensure point loading will not occur under baseplates. An optional Spreader Plate should be added beneath bases to increase surface area for delicate membranes and very heavy loads. Waterproofing membranes to be adequately protected before installation of units to prevent point loading and / or puncturing of membrane.

Pedestals are loose-laid without mechanical fixings or adhesive. Wallbarn Aluminium Profiled rails / bearers are laid onto headpieces and fixed into place using wing nut / bolt attachments through holes in the baseplate and rails.

Wallbarn I Plus single beam or double box aluminium rails should be used when installing decking and substructure terrace platform projects.

Class A decking boards / plates are mechanically fixed to Aluminium rails / bearers which sufficient gap between decking to ensure adequate drainage. Telescopic stems are twisted to alter the height of the pedestals so that the rails / bearers and then upper decking boards / plates are flat and level in height.

It is vital that designers and installers check that the strength of the decking system to ensure maximum spans are not exceeded.

For paving applications “crucifix” cross spacers / lugs, made from anodized aluminium, should be clicked into place on the headpieces. Alternative larger paving headices can be fitted to tops of headpieces using a screw.

When using the 20mm or 25mm high double box Wallbarn Aluminium Rail / bearer <https://www.wallbarn.com/substructure/class-a2-s1d0-rail-system/> pedestals should be placed a maximum of 600mm apart.

When using the 50mm high Wallbarn double box Aluminium Rail / bearer <https://www.wallbarn.com/substructure/class-a2-s1d0-rail-system/> pedestals should be placed a maximum of 900mm apart.

When using the 50mm, 75mm & 100mm high I Plus single beam Aluminium Rail / bearer <https://www.wallbarn.com/substructure/i-plus-aluminium-rail/> pedestals should be placed a maximum of 1500mm apart.

## MAINTENANCE DETAILS

Products are designed to be covered and not disturbed in the long-term. Cavities between the structural deck and the decking should be inspected at least once per year to ensure drainage channels do not become blocked and flammable material does not collect. Jets of water should be used to remove limited amounts of debris, taking care not to block up or damage drainage outlets. For large or compacted debris build-up, removal of the decking boards and removing the debris by hand or machine may be required.

## HAZARDS IDENTIFICATION

The major hazards identified for these products are physical and include manual handling. Sparks and shrapnel / fragments may be generated from cutting processes.

## FIRST-AID MEASURES

In event of cuts and damage from dropped products, wash out wound with plenty of clean water. Seek medical attention as soon as possible.

In event of bruising or impact damage from dropped products, Seek medical attention as soon as possible.

If any metal fragments, shrapnel or foreign body gets into eyes **DO NOT TRY TO REMOVE IT FROM YOUR EYE YOURSELF**. Go immediately to the First Aid Officer on site. Go to A&E / walk in clinic at a hospital as soon as possible for help.

## FIRE-FIGHTING MEASURES

These products are Class A and non-combustible. Therefore, they do not constitute a fire hazard. Use extinguishing media appropriate to the surrounding fire conditions.

## **ACCIDENTAL RELEASE MEASURES**

Damaged product can be taken up and the steel should be recycled. As supplied, the products are not classified as hazardous.

## **HANDLING AND STORAGE**

When handling product, due regard should be paid to the risks outlined in the Manual Handling Operations Regulations 1992, appropriate PPE should be used. When cutting the product with a saw, appropriate measures to control shrapnel and hot or sharp particles should be made. It is essential that full PPE is worn when doing any cutting. The product should be stored in a safe and stable manner.

## **PERSONAL PROTECTIVE EQUIPMENT:**

Suitable protective equipment and clothing are required that are appropriate to the potential hazards encountered (e.g. leather gloves, leather apron, gauntlets, safety glasses with side shields, welders helmet or welders goggles and safety boots) to reduce the chances of physical injury while using this product.

**Helmets, face shields and hand shields** should be used during all arc welding or arc cutting operations, excluding submerged arc welding. Helpers or attendants shall be provided with proper eye and hand protection.

Protective shades should be worn to protect from the intensity of light or radiant energy produced by welding or cutting operations. The exact level of shading required varies according to factors including the task producing the light, the electrode size and the arc current.

Local Exhaust Ventilation, Goggles and a dust mask to the relevant European standard (EN149) may be required if a cutting method that liberates dust is used.

## **ECOLOGICAL INFORMATION**

Subsequent to manufacture, this is a stable product with no known adverse environmental effects.

## **DISPOSAL CONSIDERATIONS**

Recycling of the steel material is preferable to disposal. If the product is to be disposed of, disposal should be made at an approved solid waste disposal site. Disposal of the product should be in accordance with any local or national regulations.

## WARRANTIES

A limited warranty exists that the products will comply with the test data as laid out earlier in document. Warranty is limited to replacement of products which have been installed in the correct manner and for the correct purpose only. Warranty is limited to the value of the cost price of the materials only, not replacement costs or any other labour cost.

## TRANSPORT INFORMATION

Classification for conveyance: - None required.

## KEY CONTACTS

Wallbarn Ltd.

Unit 16 Capital Business Centre, 22 Carlton Road, South Croydon CR2 0BS

Tel: +44 (0)208 916 2222 Fax: +44 (0)208 916 2223

Email: [sales@wallbarn.com](mailto:sales@wallbarn.com)

Web: [www.wallbarn.com](http://www.wallbarn.com)

## APPENDIX A: WALLBARN PRODUCT BROCHURE

The following table summarizes the documents referenced in this document.

Document Name	Location
METALPAD BROCHURE	<a href="https://www.wallbarn.com/fire-rated/metalpad-ex/">https://www.wallbarn.com/fire-rated/metalpad-ex/</a> v
Substructure details	<a href="https://www.wallbarn.com/substructure/our-range/">https://www.wallbarn.com/substructure/our-range/</a>
Wallbarn Ltd Terms & Conditions	<a href="https://www.wallbarn.com/terms-conditions-of-supply/">https://www.wallbarn.com/terms-conditions-of-supply/</a>