

This roofing
shingle is made of

**Super
Katepal**TM

elastomer
bitumen

SuperKatepalTM

Elastomer bitumen
roofing shingles

Product information and
installation instructions

KATEPAL

www.katepal.fi

Attention!

You can always find the newest version of these instructions on our website www.katepal.fi

Contents**PRODUCT INFORMATION**

Intended use	3
Method of application	3
SuperKatepal shingles	4
Eaves/ridge capping shingles	4
Product range and dimensions	5
Packages	6
Other materials and supplies	
Underlay membranes	6
Valley sheet Super-Pintari	6
Metal drip trims	6
Sealing Compound K-36	7
Pass-through seals	7
Ridge ventilators	7
Decking	7
Ventilation	8
Improving roof ventilation	8

INSTALLATION INSTRUCTIONS

Tools needed	9
Underlay membranes and their installation	9
Metal drip trims	11
Valleys / Super-Pintari	12
Installation of roofing shingles	
Eaves / Eaves shingles	13
Installation of roofing shingles	14
Valleys / verges	15
Waterproofing of pass-throughs	16
Upturns	16
Chimney abutment and flues	17
Ridge / ridge capping shingles	17
Special roof products	
Pass-through seals	18
Ridge ventilators	18
Walkways	18

SPECIAL INSTRUCTIONS

Working around a verandah or similar structure	19
Chimney upturn	19
Valley starting along the roof slope (e.g. lantern)	20
Starting above a bay window or a stepped eave	21
Chimney abutment of a log building	22
Hexagonal roofs	22
Installing shingles on existing bitumen shingle roofing	23

Roof maintenance	24 (back page)
-------------------------	----------------

PRODUCT INFORMATION

Intended use

Katepal elastomer bitumen roofing shingles are suitable for new construction and re-roofing of existing roof structures with a minimum slope of 1:5 (approx. 12°). The ratio 1:5 means that the roof slope has a fall of one metre over a span of five metres. The steeper the slope the more it enhances the pattern and good looks of the shingle roof. Roofing shingles can easily be installed by DIY builders, too. Bitumen roofing shingles are the easiest choice when the roof has a complex geometry. The pliable material is easy to work, and details – such as angles, penetrations, joints, seams, etc, – do not cause problems. The sealing of any joints can be made securely with Sealing Compound K-36.

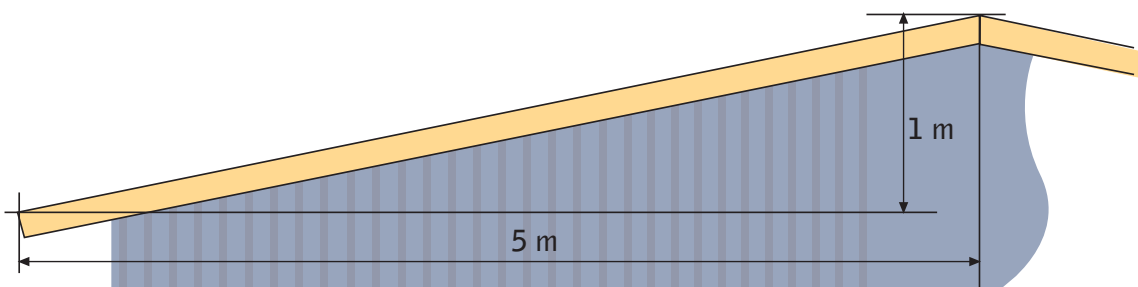

Method of application

The roofing shingles are fixed to the decking with sufficiently long roofing nails. The shingles should be lapped so that the nail heads are covered by the overlapping shingles. The bitumen adhesive on the underside will bond the shingles together, forming a watertight and continuous roofing. Installation instructions are printed on the reverse of the product label of each roofing shingle package.

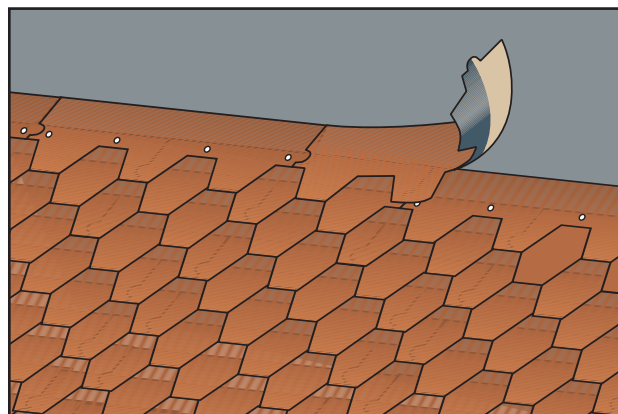



SuperKatepal shingles

SuperKatepal shingles are manufactured from SBS elastomer bitumen. The product has glass felt reinforcement, which guarantees excellent dimensional stability. Thanks to the SBS elastomer bitumen the shingles are watertight and pliable. The shingles have a surfacing of slate and/or mineral granules. The undersurface consists of self-adhesive bitumen under a protective film and a sand coated area. The granular surfacing gives the product its colour, a matt finish that blends in well with the natural and built environment, a rough friction surface, UV protection and the required fire safety properties (fire rating: B_{ROOF} (t2) and B_{ROOF} (t1)).

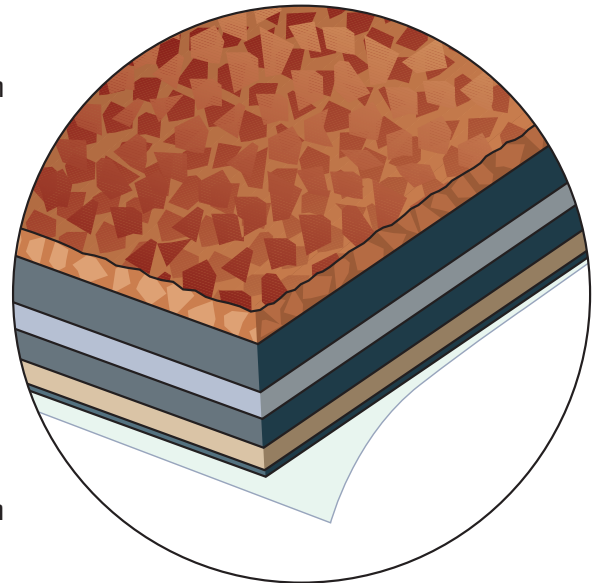

The eaves/ridge capping shingle

The eaves/ridge capping shingle is, in fact, a rectangular shingle. Similar to the standard shingle, it has a granular top surface and an underside with an adhesive part and a sand-coated part. It is used at eaves in the packaged form with butt joints.

At the ridge, the eaves shingle is folded and torn into three parts, and the shingles thus produced are laid according to the supplied instructions.

Product range and dimensions

Super Roofing Shingles are supplied in many styles, each in a range of colours. Super-KL, Super-Jazzy and Super-Katrilli have identical dimensions, while the geometry of Super-Rocky and Super-Foxy clearly differ from them.

Dimensions, Rocky

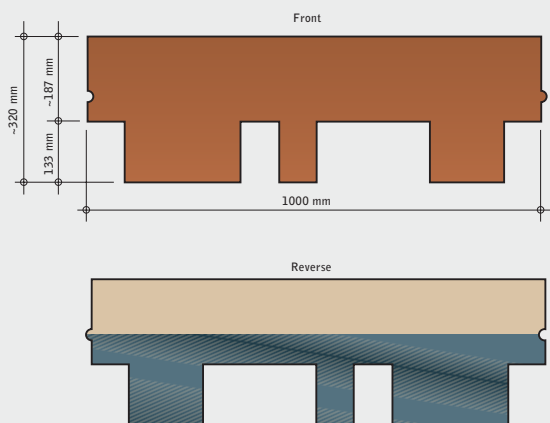

Overlapping Rocky

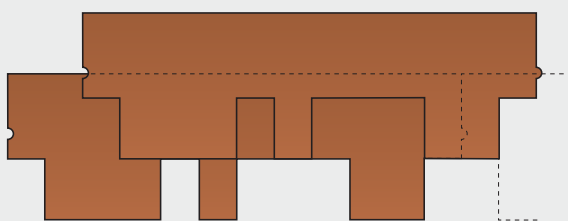

Dimensions, Foxy

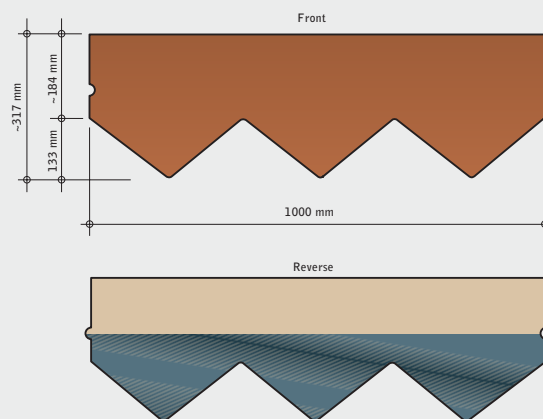

Overlapping Foxy

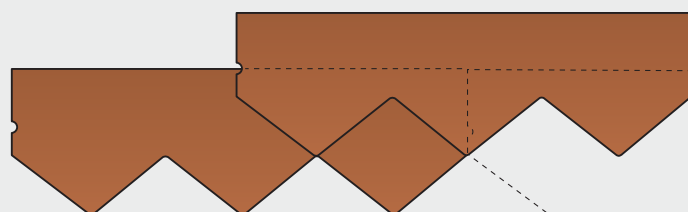

Dimensions, Jazzy, KL, Katrilli

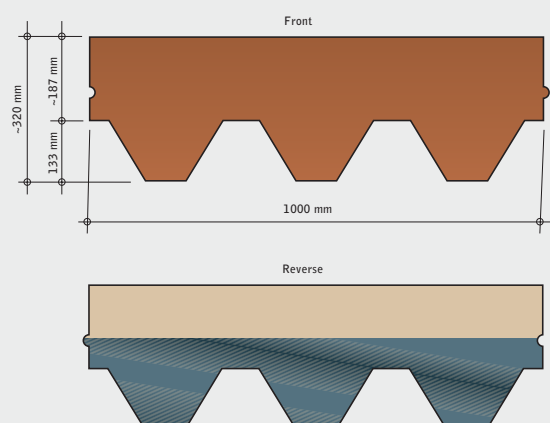

Overlapping Jazzy, KL, Katrilli

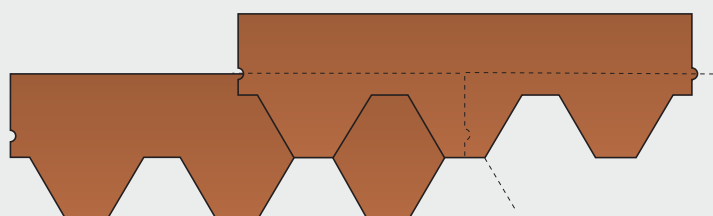

Dimensions, eaves/ridge capping shingles

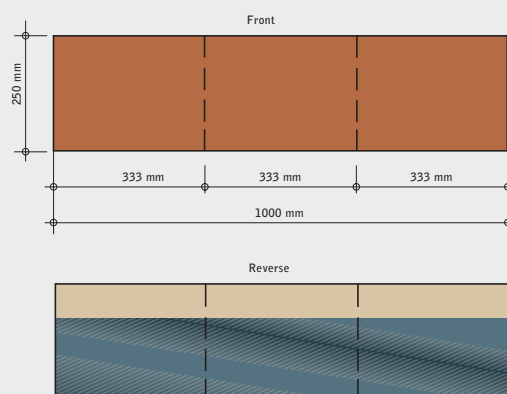

Packages

One package contains 22 shingles, i.e. 3 m² of finished roofing. Installation instructions are printed on the reverse of the product label of each roofing shingle package.

The eaves / ridge capping shingle package contains 20 eaves shingles. One package is enough for 20 metres of eave or 12 metres of ridge or hip.

Other materials and supplies needed with roofing shingles

Underlay membranes

- An underlay membrane must always be applied on board decking prior to installing roofing shingles.
- Katepal has three types of underlay membrane: Super Underlay Sheet, K-EL 60/2200 and U-EL 60/2200, all with adhesive edges.
- If roofing shingles are not installed immediately after the application of the underlay membrane (e.g. delays caused by work on chimneys, flues or other penetrations), we absolutely recommend the use of Super Underlay Sheet. This is also recommended if roofing work is postponed over the winter.
- All products have an adhesive edge that makes for quick and easy sealing of joints. All you need to do is to remove the protective film and press the surfaces together. In cold weather (below +10°C), the adhesion of the membranes should be ensured by heating the adhesive surfaces with a hot air gun, particularly when installing roofing in the autumn.
- Fix to the deck with roofing nails. Nails must penetrate through the roof deck.
- Roll size 15 m x 1 m.
- Quantity of material needed is 1.15 x roof area.

Choosing the underlay membrane for bitumen roofing shingles

Roof shape	Super Underlay Sheet (adhesive edge)	Other underlay felt
Steep sloping roofs, slope > 1:3	X	X
Moderately sloping roofs, slope 1:3 - 1:5	X	X
Demanding or complex roofs	X	
Wintertime protection during construction	X	

Valley sheet Super-Pintari

- Valley sheet membrane is used for valleys, upturns against walls and around chimneys and flues.
- Super-Pintari is a membrane manufactured from SBS elastomer bitumen and extremely tough nonwoven polyester, with a rough granular finish on the top surface. The underside has a coating of sand.
- Super-Pintari is bonded and sealed with Sealing Compound K-36 to roofing shingles and upturns.
- Roll size 10 m x 0.7 m.

Metal drip trims

- Metal drip trims are always installed at eaves. Their use is also recommended at the verges.
- Metal drip trims should be overlapped by 50 mm at extension joints.
- The length of the metal drip trims sections is 2 metres and the total width 200 mm.
- One package contains 10 sections (20m).

Sealing Compound K-36

- The elastomer bitumen-based Sealing Compound K-36 is used for the bonding and sealing of various roofing details. In the underlay membrane, such details include end joints, valleys, penetrations and upturns. In roofing shingle installation these include verges, valleys, penetrations, and similar details, as well as valleys and upturns where Super-Pintari is used.
- Sealing Compound is applied with a steel spatula or directly from the 0.3 litre cartridge with a caulking gun. Sealing Compound congeals in cold temperatures, and therefore the recommended temperature for application is $> +10$ °C. It can be used in colder weather, too, provided that the Sealing Compound itself is kept warm.
- Package sizes are 10, 3, 1 and 0.3 L.

Pass-through seals

With round penetrations (e.g. for the ventilation of sanitary pipework) we recommend the use of EPDM-rubber pass-through seals with a clamp ring attachment. These are provided for pipes with a diameter of 10 – 830 mm.

Ridge ventilators

If exhaust air ventilators from the roof space can not be installed sufficiently close to the ridge at the gables or the length of the ridge is more than 15 metres, ridge ventilators should be installed at the ridge. This type of situation arises with few exceptions in terraced housing, where firebreaks prevent ventilation in the direction of the ridge. Often this is the case with detached houses, too, and especially in the case of a hipped roof, it is important always to arrange extraction ventilation with a ridge ventilator or similar device.

Decking

- The decking for bitumen roofing shingles should be stable, unbending, smooth, and dry.
- Usually close boarding or alternatively coniferous plywood is used to make a sufficiently stable decking (Table 1).
- It is recommended that T & G boards be used for the decking (width approx. 95 mm). When using rough sawn boards (width 100 mm), they must be sturdier, have square edges, few knots, and generally be of even quality so that adjacent boards do not deflect differently.
- Extension joints must coincide with roof rafters or be otherwise supported. If using end-to-end T & G joints, there must be at least three solid boards between the joints between any two roof rafters.
- Allowance is made for the possible moisture expansion of boards and panels by leaving a sufficient gap between them. When using coniferous plywood with T & G edges, the board manufacturer's instructions for board thickness and fixing must be observed.

Table 1 Katepal requirements for minimum thicknesses of decking

Supports, c-to-c mm	Rough sawn T & G boarding mm	Rough-sawn boarding mm	Building board
600	20	22	12
900	23	25	18
1200	30	32	21

Ventilation

Ventilation of a timber roof plays an extremely important role for its functioning and durability. There must be a ventilation gap of a minimum of 100 mm beneath the roof decking. The exhaust air vents must be as high as possible (at ridge or in gable end), and if necessary, ridge ventilators should be used. There must be sufficient replacement air vents at the eaves. All ventilation openings, gaps, grilles, and vents should be equipped with netting where needed to stop birds, squirrels, etc. getting into the ventilated space. The need for ventilation is further highlighted if there are gaps or holes in the vapour barrier.

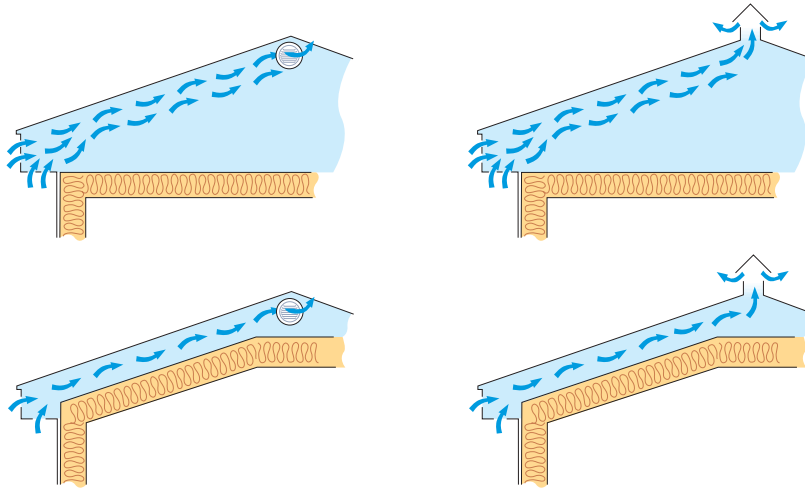

Improving roof ventilation

If the ventilated spaces are formed as "channels" between the roof rafters (roof joists) leading from the eave to the ridge, there must be a continuous open longitudinal channel under the ridge so that air from ventilated spaces between all the roof rafters can escape through it. If ventilation in the direction of the ridge cannot be made to function otherwise, the roof structure must be altered so as to bring the ridge level higher.

Old construction with poor ventilation

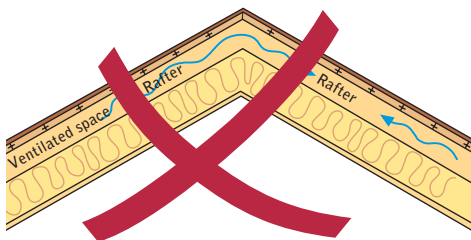

Proper ventilation

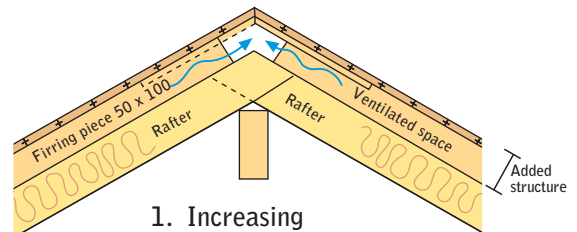

1. Increasing rafter thickness with furring piece

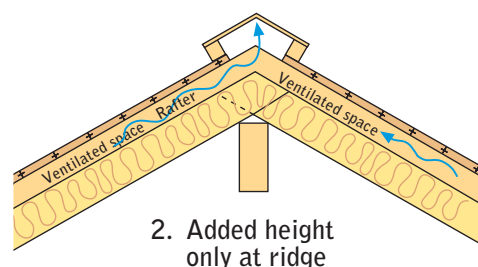

2. Added height only at ridge

INSTALLATION INSTRUCTIONS

Tools needed

No special tools are needed for the installation of SuperKatepal elastomer bitumen roofing shingles. A hammer, tape measure, hook-end knife and steel spatula are sufficient. A brightly coloured alignment string helps you to check necessary alignments. In addition, sheetmetal shears are needed for the installation of flashings.



Underlay membranes and their installation

- Katepal underlay membrane must always be installed under bitumen roofing shingles.
- If roofing shingles are not installed immediately after the application of the underlay membrane (e.g. delays caused by work on chimneys, flues or other penetrations), we absolutely recommend the use of Super Underlay Sheet. This is also recommended if roofing work is postponed over the winter and the waterproofing consists of the underlay, or the roof geometry is complex or otherwise challenging (See table "Choosing the underlay membrane for bitumen roofing shingles" on page 6).
- The underlay membrane can be installed parallel or perpendicular to the roof deck boarding (Fig. 1 a and Fig. 1 b). The sheet is unrolled, positioned correctly in a straight line, any slack is removed, and the sheet is nailed to the deck with roofing nails along the edge that will be overlapped by the following sheet (also hidden ends are to be nailed).
- On steep roofs, vertical installation is easier as there is less risk of creasing. To avoid creasing, the membrane must be absolutely straight and sufficiently tight. If installation work is carried out in cold weather, particular attention must be paid to tightening the sheets.

See more detailed installation instruction on next page.

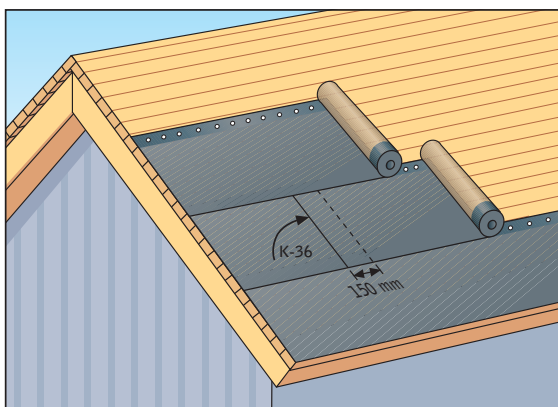

Fig. 1 a

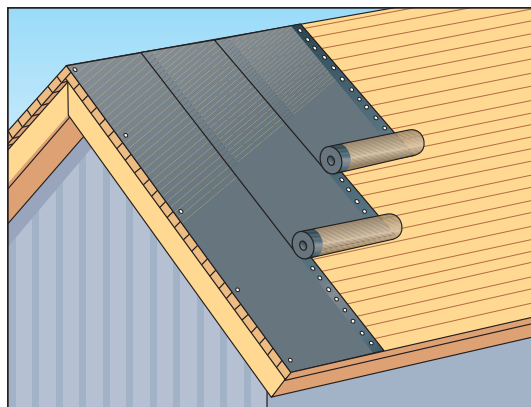

Fig. 1 b

- Each roll packaging includes installation instructions.
- The installation of the underlay membrane starts from the valley (Fig. 2).
- The underlay membrane is installed directly on the deck boarding. The metal drip trims at the eaves are installed only on top of the underlay (Fig. 2).
- If the verge detail includes a raised edge, the blocking pieces must be installed before the underlay, which is then laid over the verge to form a drip edge (Fig. 3 a and Fig. 3 b).
- On the ridge the underlay sheets of the first slope are cut along the ridge, and then the upper edge is nailed to the deck. The underlayment of the opposite slope is then taken 150 mm over the ridge and bonded to the surface of the underlay membrane of the first side with Sealing Compound K-36 (Fig. 4).
- At upturns the underlay membrane is taken at least 50 mm above the roof surface, and the upturned part is then nailed and/or bonded to the substrate if necessary (Fig. 5).

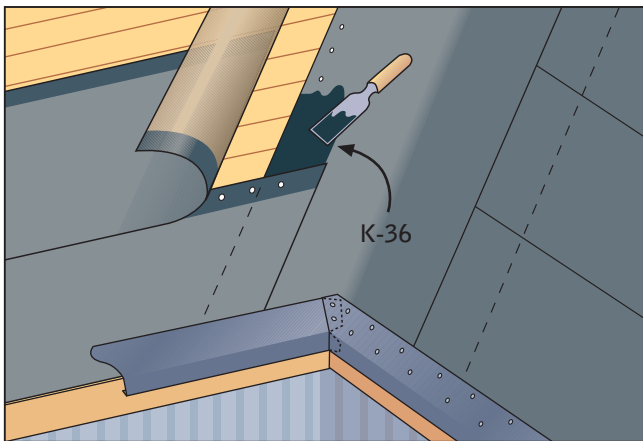

Fig. 2

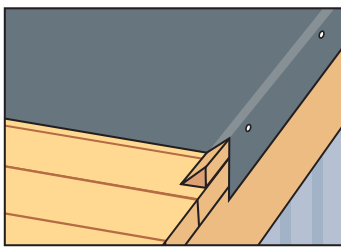

Fig. 3 a

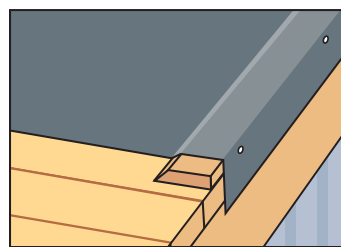

Fig. 3 b

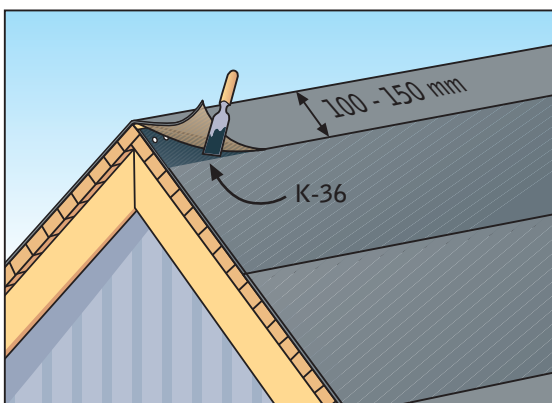

Fig. 4

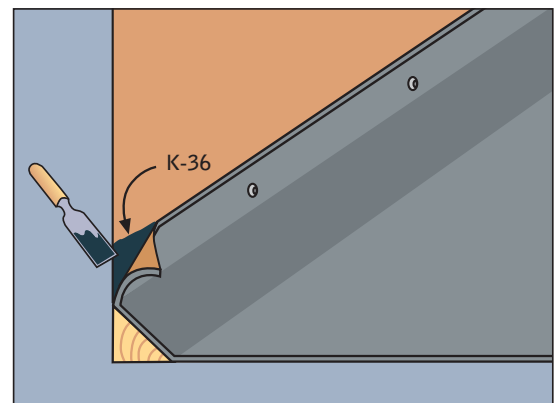
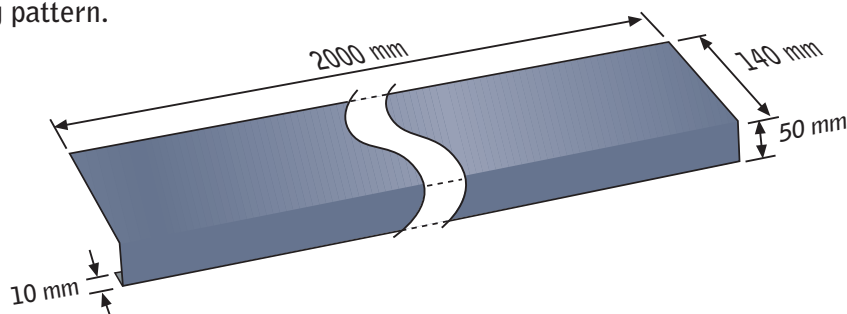

Fig. 5

Metal drip trims

- A metal drip trim is installed over the underlay membrane, at eaves without exception and usually at the verges (if a blocking piece is not incorporated into the verge detail). Metal drip trims are fixed to the decking through the underlayment with roofing nails or alternatively with flat or half-round headed screws at 10 cm spacings in an alternating zigzag pattern.



- If it is unacceptable having the nail tips show through the eave soffit, sufficiently short screws with wide and flat heads (KFR screw) are to be used.
- It is recommended that at the verges the drip edge be folded to an angle of 90° so that the fascia edge points straight down.
- Drip edge extension joints are overlapped by 50 mm and sheetmetal shears are used to cut away the folded edge that forms the drip and a bevelled piece from the bottom edge of the section that is pushed under the previous section. Two nails (or two screws) are driven through both metal sections at the overlap.

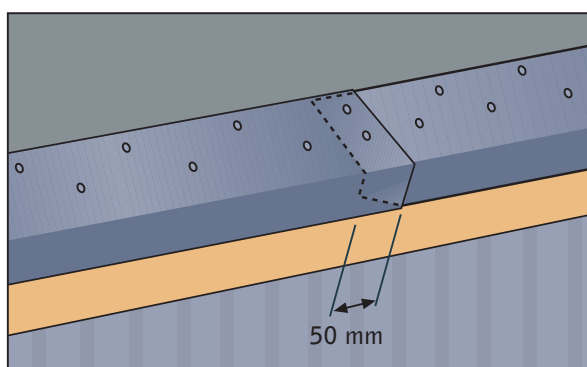

Valleys / Super-Pintari

- After the installation of the underlay membrane and the drip edges, valley sheets are installed over the valleys. The valley sheet (Super-Pintari) is laid over the underlay sheet along the valley center line. It is particularly important to ensure that the membrane is fully against the substrate along the bottom of the valley, so that no tensile stresses will result from a layer of snow/ice, or while moving about on the roof. The edges of the valley sheet are glued to the underlay with Sealing Compound K-36, and any slipping during work is prevented by nailing the sheet to the substrate.
- At eaves, the valley sheet is bonded to the metal drip trim. Any extension joints are also bonded with Sealing Compound K-36. At the point of the roof slope where the valleys meet, the valley sheets are overlapped crosswise so that water cannot penetrate into the joint between them. Where the valleys end at the ridge, the valley sheets are cut along the ridge and the top ends are nailed (in this case the nail heads are covered with ridge capping shingles).

If the bottom end of the valley is at any point along the slope (lanterns and similar structures), the valley sheet is only applied when the installation of the roofing shingles has progressed to the level of the bottom end of the valley.

See page 20 of the Special Instructions section for detailed installation instructions.

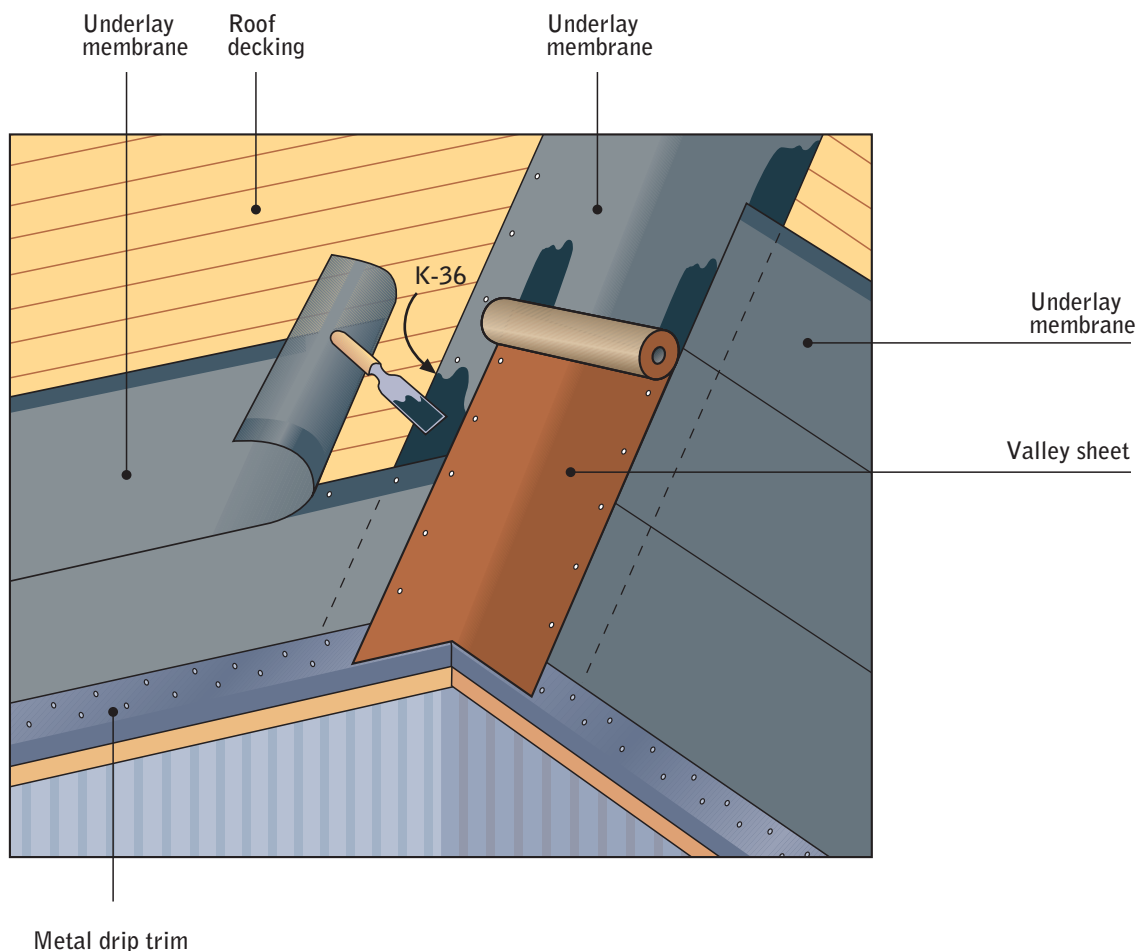

Installation of roofing shingles

Eaves / Eaves shingles

Eaves shingles are installed over the metal drip trims. The release film over the adhesive surface is removed and the eaves shingles glue end is pressed against the metal drip trim so that some 10 mm of its slope-side surface is left visible.

- Eaves shingles are installed in sequence and the ends are butt jointed without any gaps.

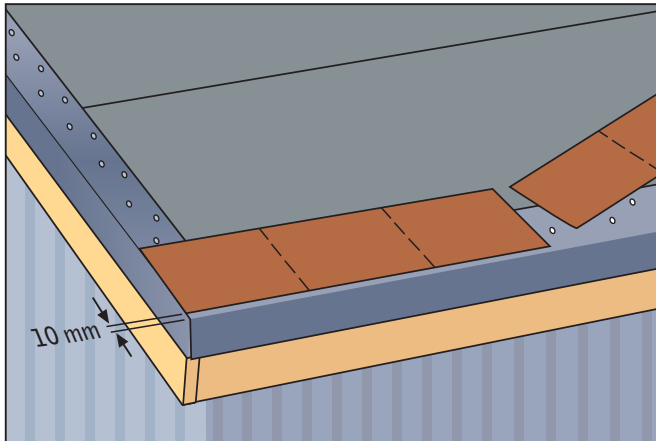

- If the eave line is not straight and unbroken (above bay windows, small verandahs with a return roof, etc.), the distance between the ends of the eaves shingles on the opposite sides of the return roof must be divisible by 1 metre (measured above the structure). This enables the correct alignment of the shingle pattern above the return roof. Usually the dimensioning has to be done by marking out perpendicular reference lines over the return roof as shown below. See separate instructions: "Working Around a Verandah or Similar Structure", page 19.

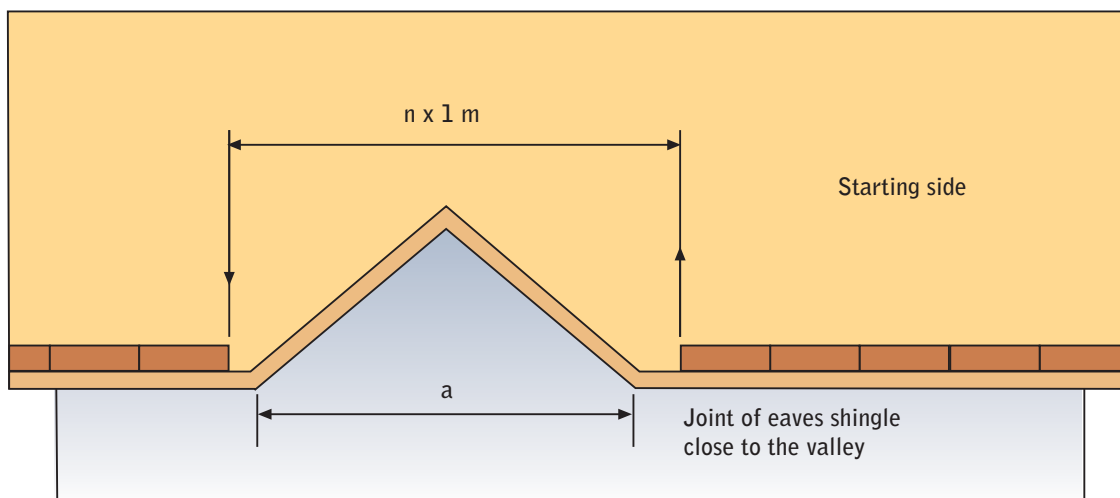

Above $n = (a+1)$ rounded up to the next full number in metres
 E.g. if $a = 3.5$ m, $n = 5$

Installation of roofing shingles

- During installation always mix the shingles at least from 4 to 5 randomly chosen bundles to minimize harmful color differences.
- It is not recommended to install shingles from different production batches on the same visible roof surface. If it cannot be avoided for any reason, the shingles from different batches must be mixed and the possible color (difference) shall be checked continuously during installation.
- The installation of roofing shingles is usually started from the middle of the slope, so that the tabs of the shingles cover the end joints and perforations of the eaves shingles. The lower edge of the first row of shingles is aligned 10 – 20 mm above the bottom edge of the eaves shingles, so that the line of the eave appears clean and straight when seen at an upward angle from the ground.
- The roofing shingles are fixed with roofing nails (4 pieces / shingle) as shown in the figures below, some 30 mm (Foxy 50 mm) above the bottom of each notch along their centre lines. Roofing nails applied manually or with a pneumatic nailer may be used. Nails must penetrate through the roof deck boarding.
- If visible nail ends are not accepted on the underside or they might be harmful (play house, attic space used for some purpose, etc.), screws of suitable length and with flat and wide heads (KFR screw) may be used for fixing the roofing shingles.
- The shingles will bond to one another, but they are nailed to the substrate. The shingles must be bonded carefully to the substrate at roof valleys (to the valley sheet), at verges (to metal drip trims or to the underlay if a blocking piece is used to raise the edge) and at penetrations (to the sleeve flange).

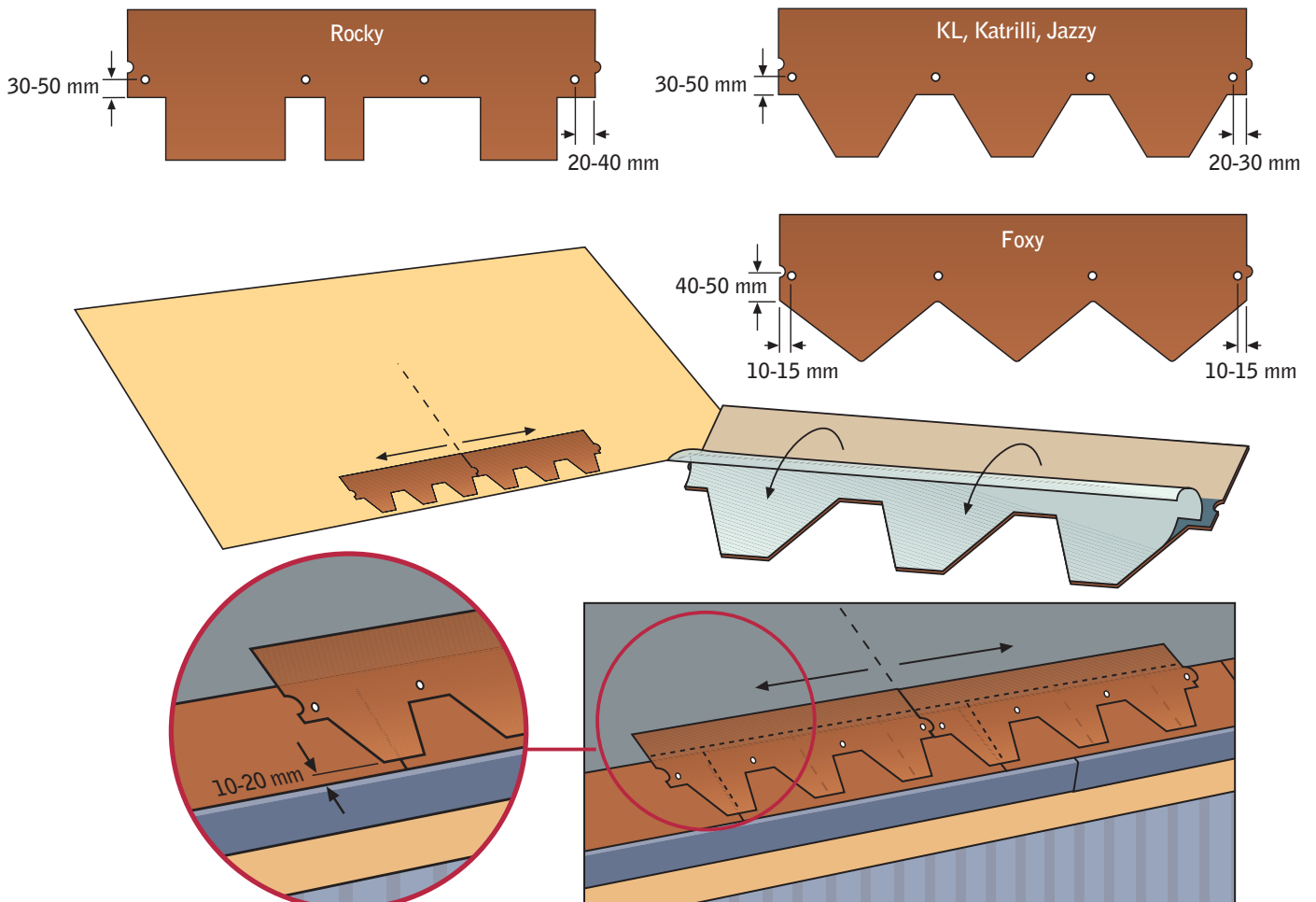

Valleys / verges

- At valleys the ends of the shingle are cut parallel to the valley, ensuring that the shingles overlap the valley sheet by at least 150 mm.
- Usually a 100–200 mm wide area along the bottom of the valley sheet is left exposed. The ends of the shingles are bonded to the valley sheet with care so that any water accumulating in the valley can not seep under the shingles.
- It is not recommended to nail shingles to the decking on top of the valley sheet. The shingles should be glued to the valley sheet with Sealing Compound K-36, applied to a minimum width of 100 mm as measured from the mitred edge of the shingle.
- At the verges, the shingles are cut along the verge line and the ends are bonded to the metal drip trim. When an upstand is built at the verge, the ends of the shingles are bonded along the blocking piece (the chamfered surface) to the underlay, and a metal flashing of separate specification is attached on top.

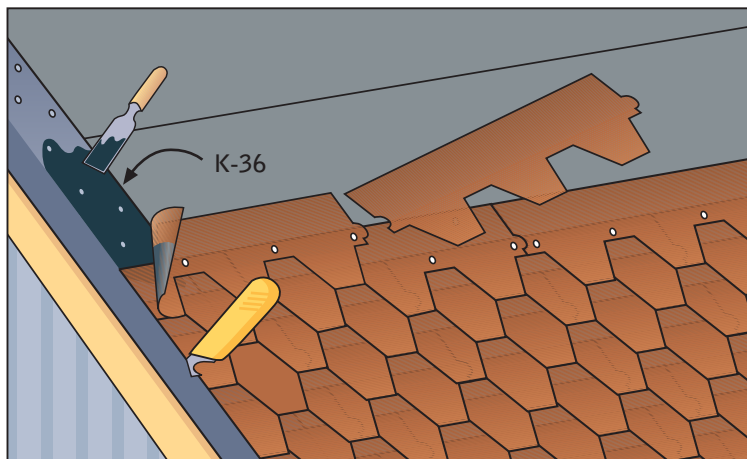
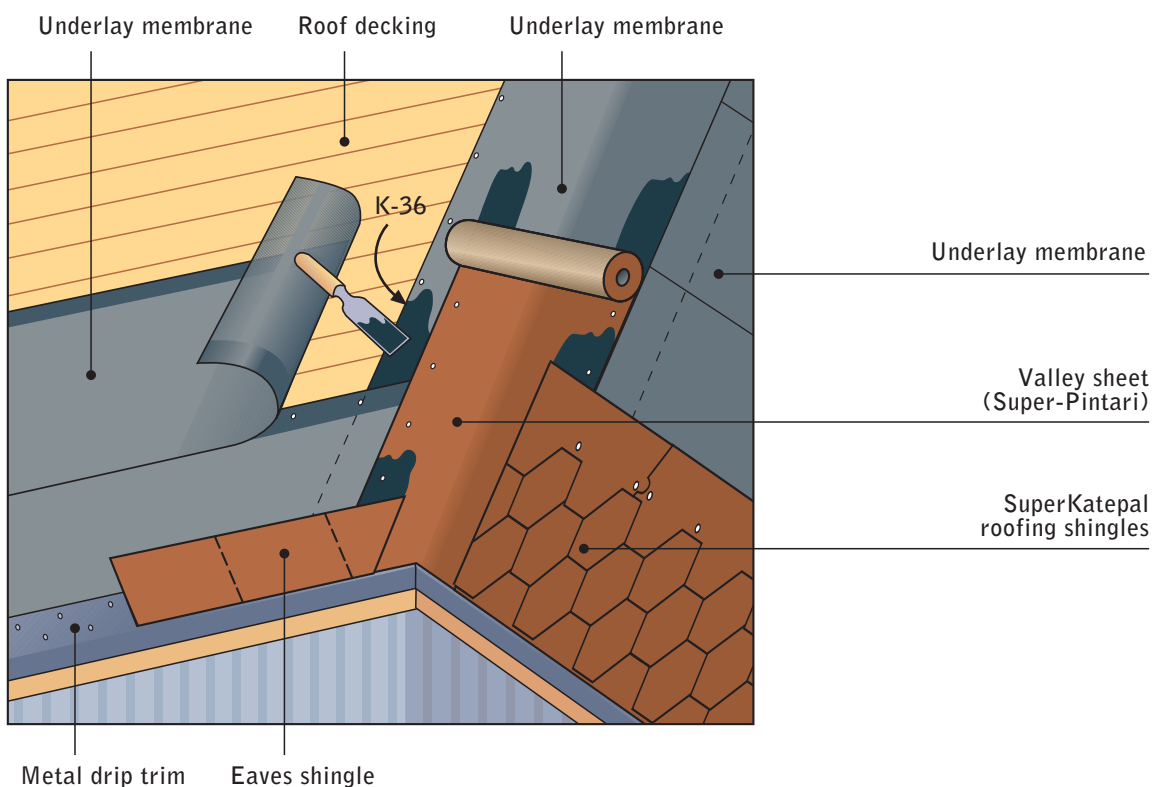

Alternatives for making the upstand and attaching the metal flashing at the verge.

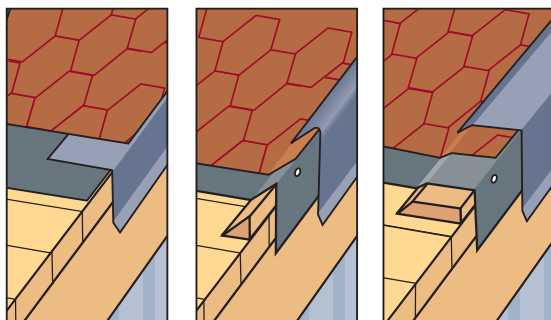

Waterproofing of pass-throughs

- With round penetrations (e.g. for the ventilation of sanitary pipework) EPDM-rubber pass-through sleeves with flanges are used.
- The flanged sleeve is slipped over the pipe, bonded to the underlay and nailed with 4–5 nails to the decking to prevent it sliding downwards.
- Cutouts matching the rubber seal standing above the roof surface are made for the shingles and they are bonded carefully to the flange underneath.
- Any gap/groove between the shingles and the sleeve is sealed with Sealing Compound K-36.
- When using other types of seals the same principle should be followed and the manufacturer's instructions observed.

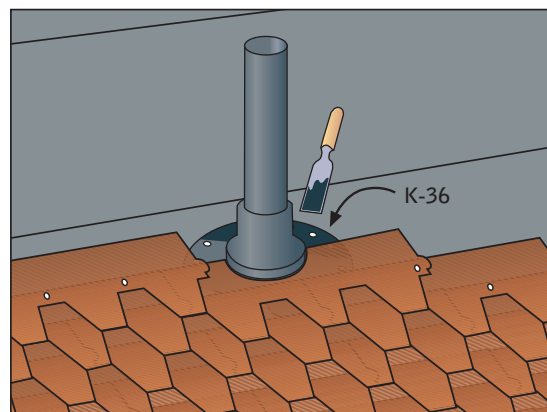
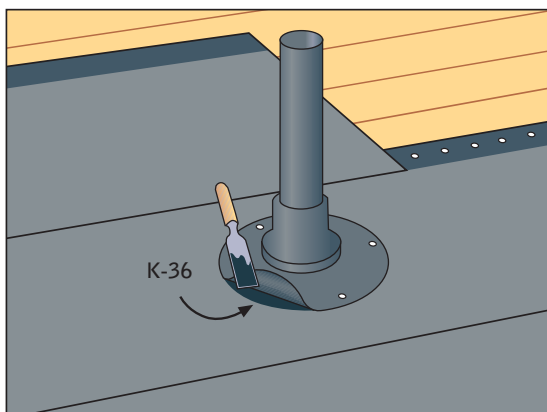

Upturns

- An upturn usually rises 300 mm above the roof surface.
- An angle fillet is installed along the abutment of a side wall and roof slope.
- The underlay and shingles are folded and brought to the upper edge of the fillet or 50 mm up the wall surface.
- The actual upturn is made with Super-Pintari membrane, which is bonded to the wall and roof surfaces by applying Sealing Compound K-36 over the whole underside and securing the top edge with nails. The maximum thickness of the Sealing Compound layer is 0.5 - 1 mm.
- The top edge of the upturn is covered with wall cladding or metal flashing.

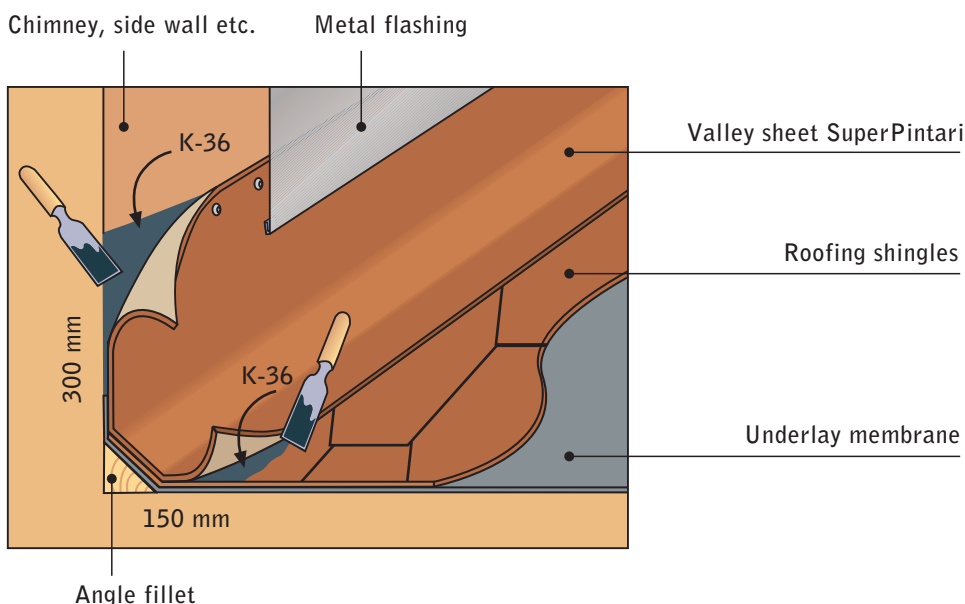

Chimney abutments and flues

- Angle fillets are first installed at the abutment of the roof and vertical surfaces.
- It is recommendable to build a counter-slope in the roof decking at the head of a penetration for a wide chimney or set of flues, so that water does not accumulate behind the chimney (Fig 1).
- The underlay and shingles are folded and brought to the upper edge of the fillet.
- The actual upturn is made with Super-Pintari felt according to Fig. 2, see also page 19.
- The upturn pieces are bonded to the chimney and the roof surface on top of the shingles, taking particular care in sealing the corners.
- Material quantity needed: The amount of Super-Pintari needed equals the circumference of the chimney (measured along the roof slope) + 1.6 m / chimney.
- Construction of a chimney and roof abutment of a log building: see page 21.

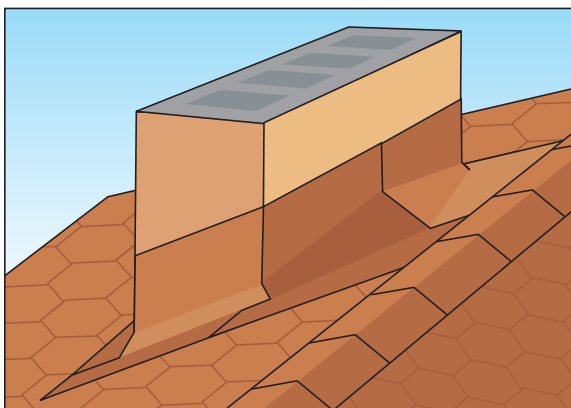

Fig. 1

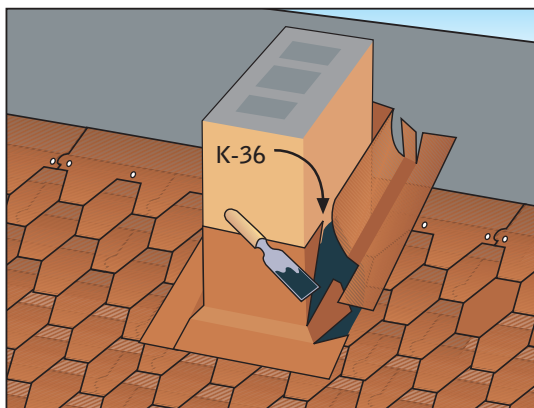
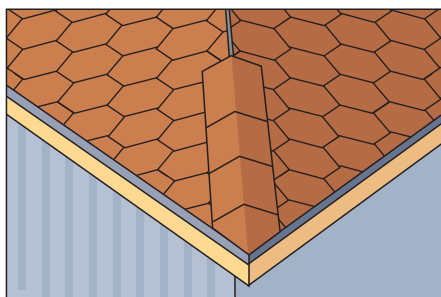
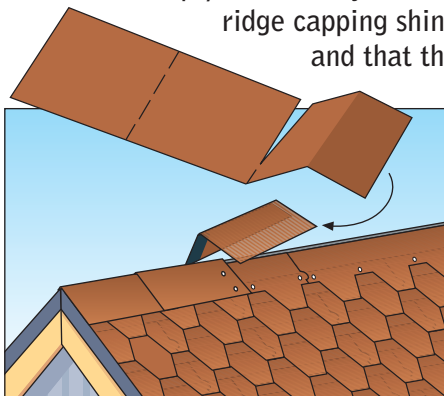

Fig. 2

Ridge / ridge capping shingles

- On the ridge, the topmost shingles are cut along the ridge line (not folded over the ridge!).
- By folding and tearing an eaves shingle as shown below, you will have three ridge capping shingles.
- On a pitched roof, installation is started from either end so that the adhesive edge of the first ridge capping shingle is aligned along the verge, on top of the roofing shingles. The ridge capping shingle is nailed to the decking from the non-adhesive edge with four nails.
- Ridge capping shingles are laid centrally on the ridge in such a way that the adhesive strip on the underside overlaps the previous sheet by some 50 mm covering the nail heads. The procedure is repeated along the length of the ridge.
- The last ridge capping shingle is fixed at the opposite verge without nailing. If necessary, Sealing Compound K-36 may be applied on the non-adhesive part.
- On hipped roofs the installation of ridge capping shingles starts from the eaves ends of the hips, followed by the ridge sections. At the points where the hips meet, the last ridge capping shingles are folded so that rainwater can not get under them and that the ridge shingles overlap them.



Special roof products (not included in Katepal's delivery)

Pass-through seals

Manufactured EPDM-rubber seals are installed over the underlay, and the shingles are carefully bonded over the flange. The upper edge of the seal is tightened over the penetrating pipe with a metal clamp at such a height that the seal does not pull the shingles up if the pipe moves. Rectangular pass-through seals are also available, but we recommend the use of circular pass-through fittings.

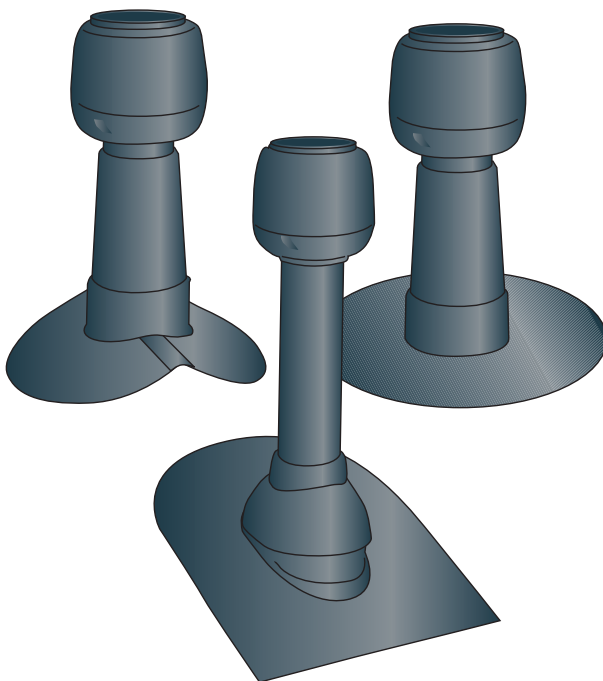
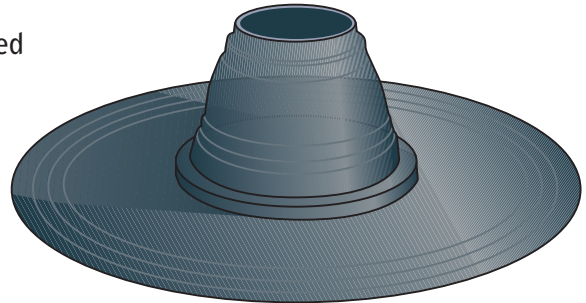

Ridge ventilators

Plastic ridge ventilators are the most common type. The ventilator is usually installed on the ridge or right next to it. The ridge ventilator types generally supplied include ridge types as well as slope types for various pitches, with straight or angled flanges.

A ridge ventilator should be installed over the underlay and fixed with adhesive and nails. A piece the size of the ventilation pipe is cut out of the shingles and they are carefully bonded over the flange. The size of the ridge ventilator (the diameter of the pipe) is determined by the necessary ventilation rate

Walkways

Walkways should always be installed as high up on the slope as possible. We recommend the installation of pressure impregnated wood attachments under the metal supports. They should be installed upright on the roof so that water does not accumulate behind them. The joint between the wood attachments and the roofing should be sealed with Sealing Compound K-36.

Snow barriers

On elastomer bitumen roofing, with granular mineral surfacing, no snow barriers are usually needed. Snow does not slide down even from steep roof slopes. If snow barriers are installed, particular care must be taken to seal the fixing points securely.

SPECIAL INSTRUCTIONS

Working around a verandah or similar structure / alignment of shingles above the structure

If a verandah, balcony, or similar structure is located along the slope so that the sections of roofing starting from the eave join above the structure, the joints of the roofing shingles (and eave shingles) must be aligned correctly. The dimension between the vertical joints on opposite sides (measured "over" the structure) must be divisible by 1/3 metres with KL, Jazzy and Katrilli formats, and by exactly 1000 mm with Rocky shingles.

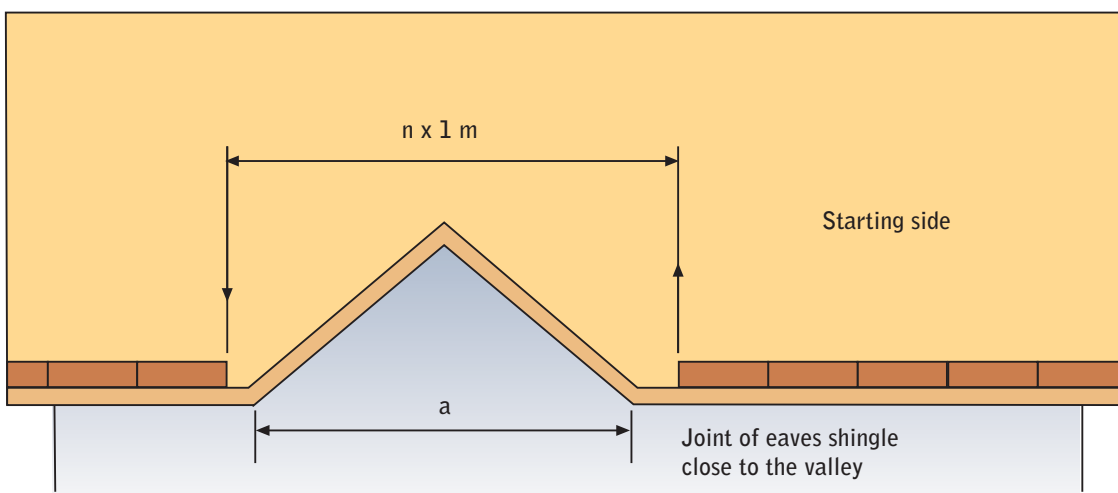
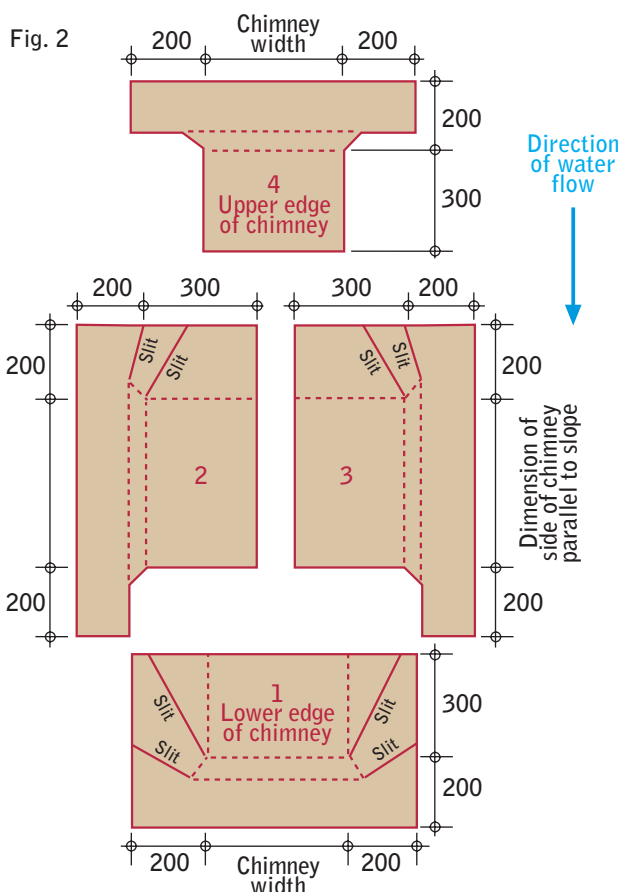

Fig. 1 Above $n = (a+1)$ rounded up to the next full number in metres. E.g. if $a = 3.5$ m, $n = 5$

Chimney upturn

Once the installation of roofing has progressed to the level of the upper edge of a chimney or other significant penetration, cut the upstand pieces out of a sheet of Super-Pintari according to Fig. 2 and glue them with Sealing Compound K-36, in the order indicated by the numbers, across their whole width to the chimney and over the roof slope sheets (overlap 15 cm). Above the chimney, the edge of the strip is placed under the cap sheets of the roof slope. Before the strips of the upstand are installed in place, a cove is made at the abutment by using angle fillets. Make sure to seal the upstand corners carefully with Sealing Compound K-36 and finally protect the upturn with sheet metal flashing.



Valley starting along the roof slope (e.g. lantern)

Horizontal installation: If the valley ends somewhere along the sloping face instead of the eave, the valley underlay should be installed only after the installation of the underlay on the slope has progressed to the lower end of the valley. The valley underlay should overlap the membrane below by at least by 150 mm. After this stage the installation of the slope underlay can be continued. The sheets should overlap the valley underlay by 150 mm. At valleys, the sheet overlaps are to be sealed with Sealing Compound K-36.

Vertical installation: Underlay sheets are first installed on both sides of the lantern and below it. After this, place one underlay sheet along the bottom of the valley and overlap its lower end 150 mm on the previously assembled underlay sheet. The underlay sheets above the lantern should overlap the valley sheet.

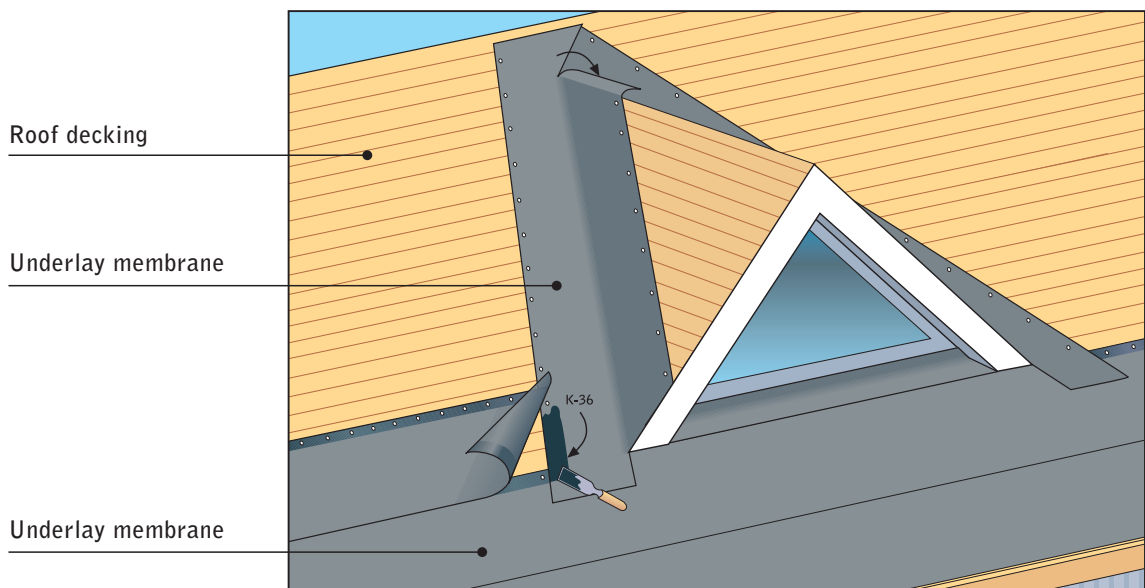

The roofing shingles are then installed up to the lantern and lower end of the valleys. After this stage, the valley sheet (Super-Pintari) is installed so that its lower end overlaps the shingles by 150 mm. The lower end of the valley sheet should be glued carefully to the shingles with Sealing Compound K-36. Installation of roofing shingles is then continued in the standard manner so that they overlap the valley sheet, their ends are cut parallel to the valley and are glued to the valley sheet with Sealing Compound K-36.

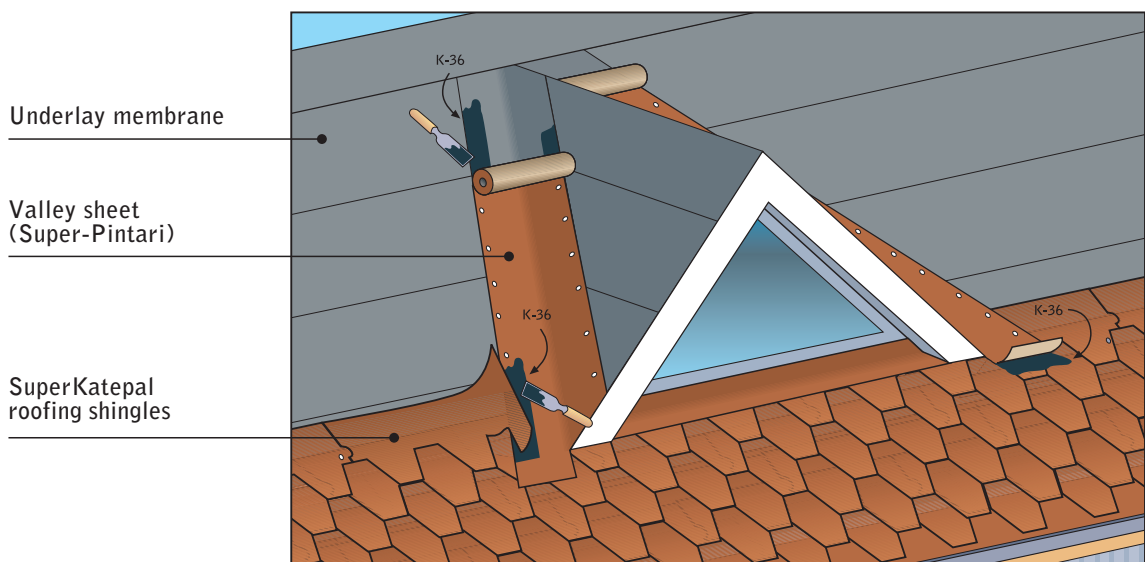

Starting above a bay window or a stepped eave

When laying shingles, the start line at the lower end of a bay window in the middle of or at either edge of a roof slope is dimensioned so that the line of the actual eave is taken as the 0-line from which n number of rows (133 mm / row) are calculated downwards. At the first shingle row, the necessary pieces are cut away from the shingle ends.

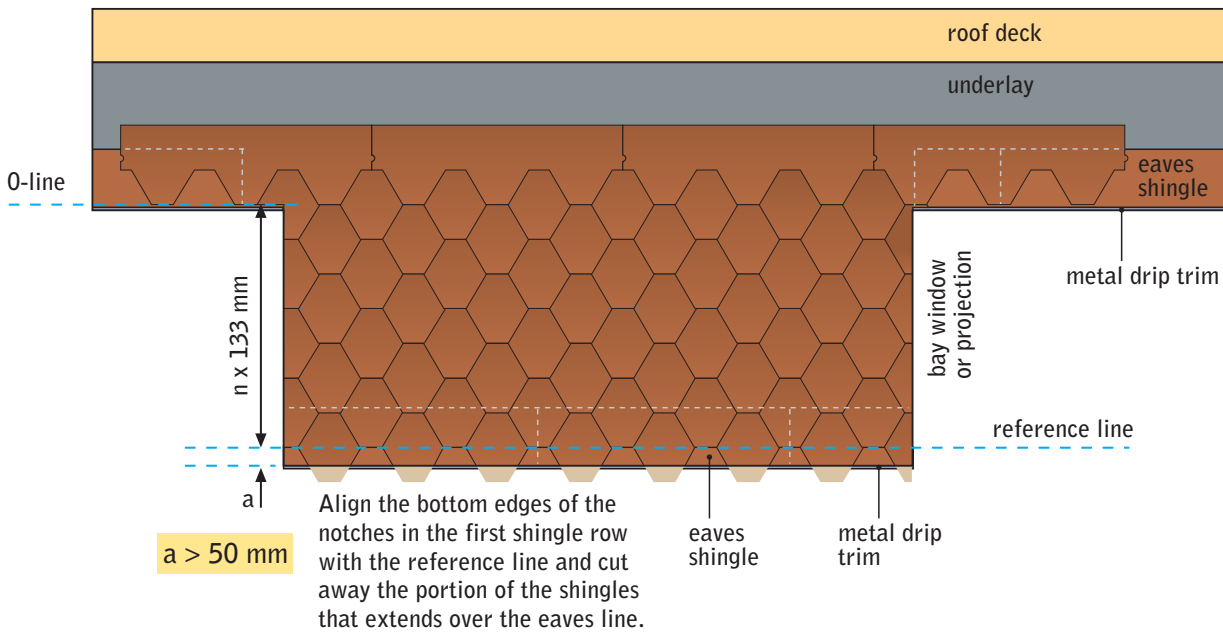

If dimension a is $\leq 50 \text{ mm}$ (picture below), the first row of shingles can be started from the reference line up.

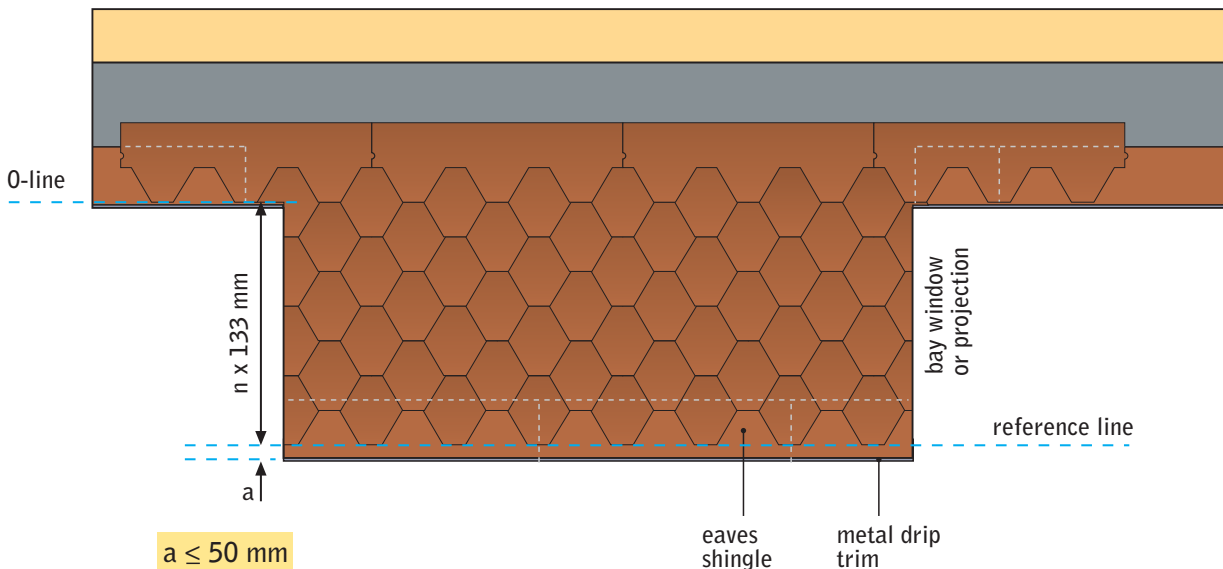

In the sideways direction the eaves sheets are not necessarily positioned in a corresponding manner at the verge of the bay roof and the eave. With the KL, Jazy and Katrilli types the sideways shift may be $1/6$ of the length of the shingle (i.e. 166 mm) and with Rocky shingles multiples of $1/12$ shingle lengths (i.e. 83 mm intervals over the length of the entire shingle), depending on how many rows of shingles fit on the bay roof.

Chimney abutment of a log building

In a building with a log frame it must be noted that, as the frame settles, the roof descends in relation to a masonry chimney. The membranes may not be fixed to the chimney, instead a frame is made, against which the membranes are turned up. The flashing of the chimney is fixed to the chimney, overlapping the upturn by a minimum of 200 mm. The flashing may not be fixed to the roof surface or the membranes. In this way the frame and the upturn can settle with the roof without damage. The chimney flashing covers the gap between the upper edge of the upturn and the chimney, despite settling of the building.

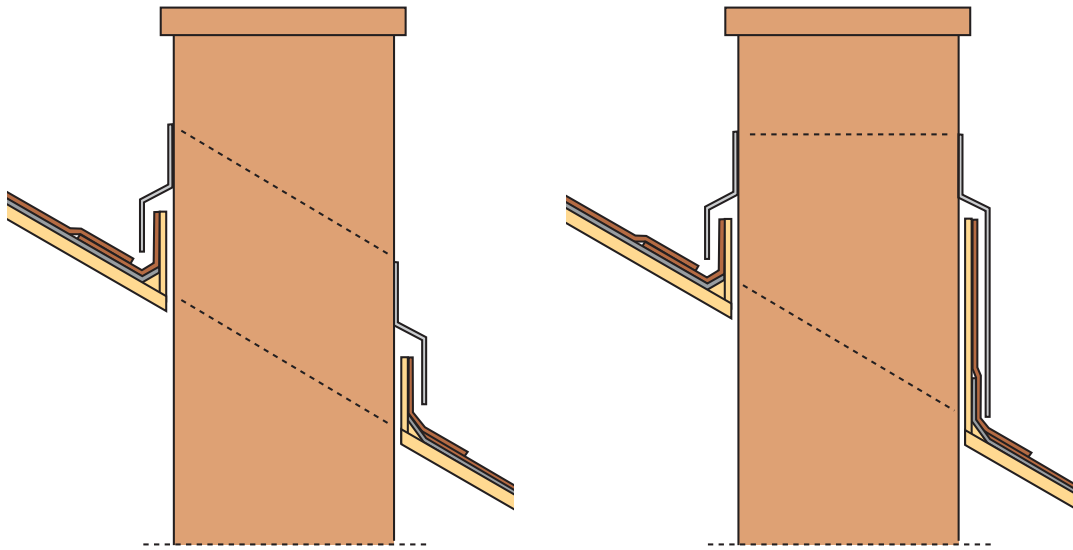

Hexagonal roofs (barbecue shelters, conical huts etc.)

With KL, Jazzy and Katrilli shingles it is practical to mark out the centre line for each triangular section from the eave to the ridge point. The centre butt joint of first shingle row should be in line with the centre marking line. Thereafter the centre butt joint of every second row should be in line with the marking line. In this way, the pattern will be identical on all triangular sections.

The roof is covered one triangular section at a time, in a way similar to the roofing of the hipped ends of hipped roofs. Ridge capping shingles are installed over the hips.

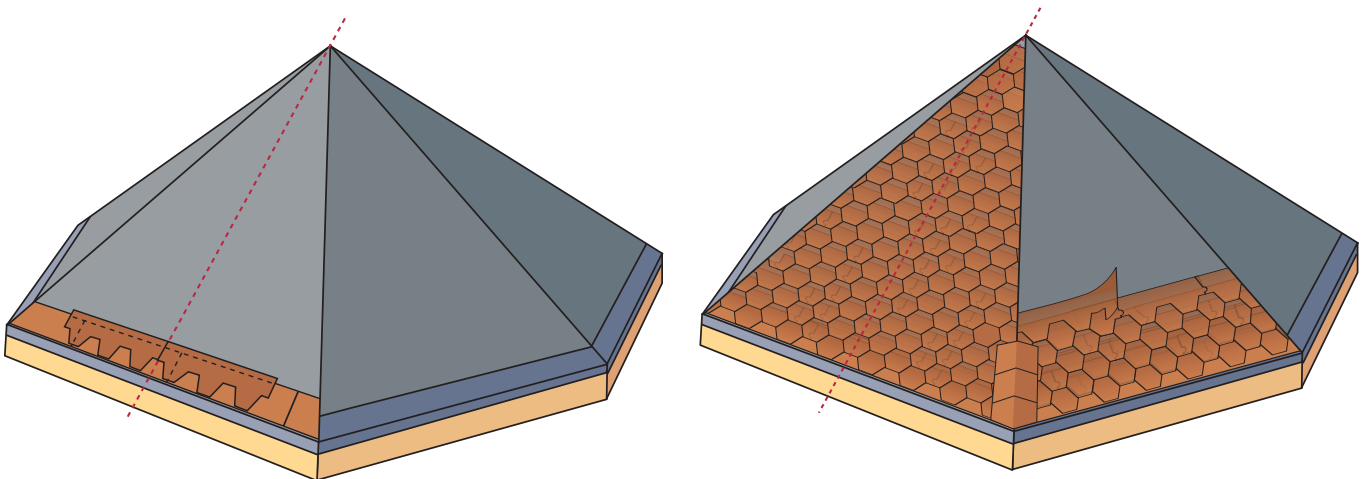

Installing shingles on existing bitumen shingle roofing

A roof with old bitumen shingle roofing can be reroofed in three different ways

1. New shingles directly over the old ones - a quick and cheap alternative.
2. The old roofing shingles are dismantled, and a new underlay and new shingles are applied.
A thorough alternative in connection with which it is easy to renew the whole decking or repair parts of it.
3. A new underlay and new shingles are applied over the old shingles.

Installing new shingles directly over the old ones

New roofing shingles of a matching model can be installed directly over old KL, Jazzy and Katrilli bitumen shingles under the following conditions:

- The decking under the old roofing is in good condition and the roof space is sufficiently ventilated.
- The going/shingle row of the new and old shingles is almost the same (max. deviation 10 mm).
- An underlay has been installed under the old shingles (min. pitch 1:5), or without the underlay, the pitch is no less than 1:3.
- New shingles are fixed with roofing nails that penetrate through the decking.
Minimum nail length is usually 35 mm.
- The shingles are overlapped as instructed below, so that the position of the shingles and the points of fixing alternate in the correct manner. The nails of the new shingle roofing must not coincide with the gaps of the old roofing pattern.

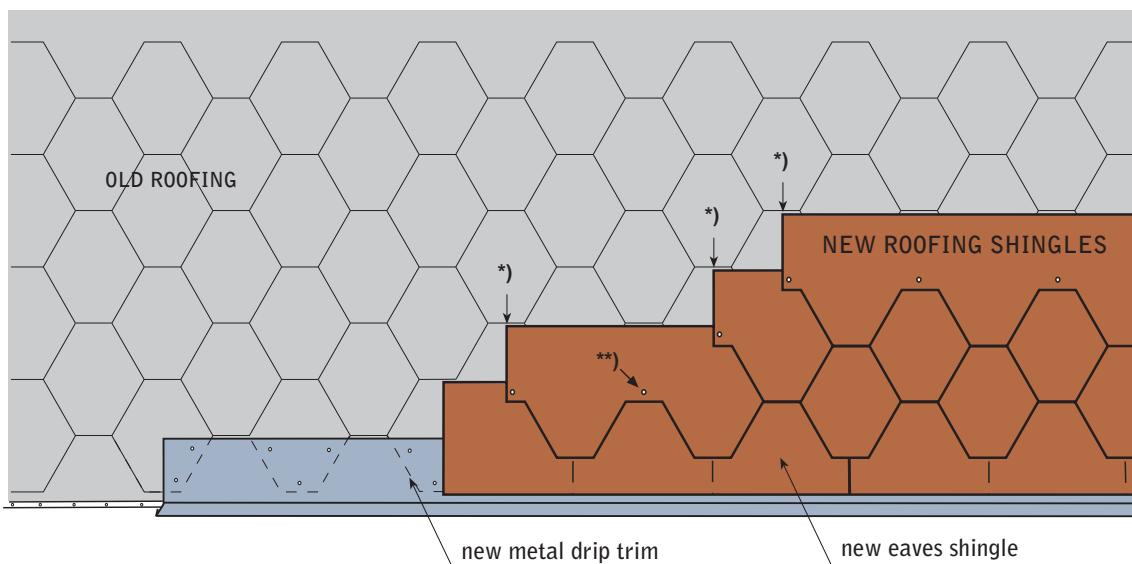

*) A gap of 5–10 mm should be left between the tip of the old shingle and the back edge of the new shingle. The vertical joint of the new shingles should be aligned with the centre of the tip of the old shingle.

**) Nail length should be specified so that the nail penetrates the roof deck (usually 35 mm roofing nails).

Roof maintenance

Elastomer bitumen shingle roofing is easy to maintain and durable. No painting or coating is necessary. Usually regular inspection, observing the following instructions, is a sufficient maintenance measure.

- Inspect the roof at regular intervals, at least twice a year (spring and autumn).
- Remove any debris from the roof (leaves, moss, etc.) by light sweeping without damaging the surface.
Tree branches etc. are best removed by hand.
- If necessary, use appropriate chemicals to remove moss.
- Ensure that water runs off the roof unobstructed.
Clean the gutters when necessary.
- Remove snow from the roof only when it is absolutely necessary. Even then, leave a 10–20 cm layer of snow on the roof. The roof surface may not be damaged with a shovel or other tools. Ice may not be removed mechanically, e.g. by chopping.
- When working on the roof the roof surface must be protected.
- When you detect the need for repair, do not delay the work, in order to avoid more extensive damage.
- Where necessary, seal joints and penetrations with Sealing Compound K-36.
- Avoid unnecessary movement on the roof.
- In case of any queries, please contact Katepal's technical support.

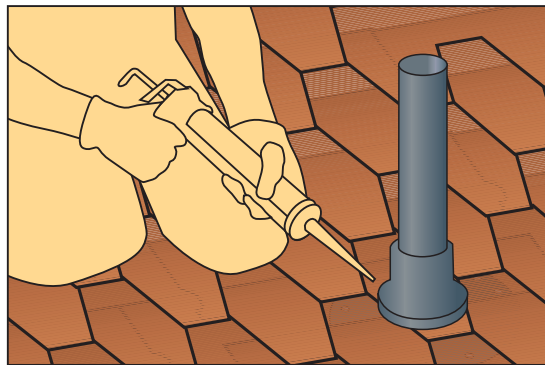
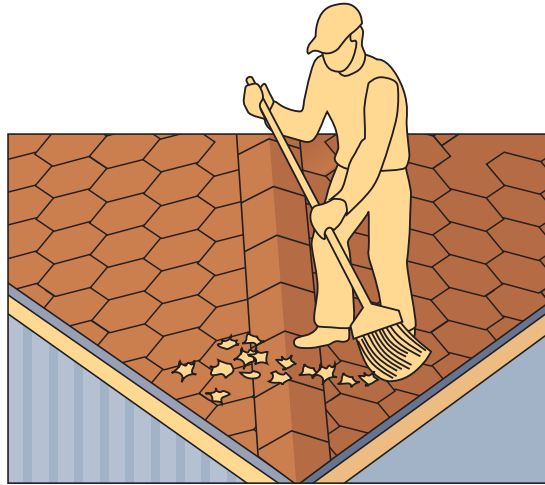

KATEPAL
www.katepal.fi

Katepal Oy, P.O. Box 33, FI-37501 LEMPÄÄLÄ
Customer service +358 (0)3 375 9111
Fax +358 (0)3 375 0974
E-mail: katepal@katepal.fi
www.katepal.fi