

# HardRock® Multi-Fix (DD)

Non-combustible insulation for flat roofs.

HardRock® Multi-Fix (DD) is a stone wool insulation board faced with a mineral-coated white fleece, compatible with a wide range of adhered and mechanically fixed waterproofing systems – including bitumen, single-ply, EPDM and liquid membranes, as well as green roof systems.

- Presents no smoke hazard, and will not contribute to fire growth in any stage of a fire (including the fully developed stage of a fire).
- HardRock Multi-Fix (DD) is non-combustible, and achieves a Euroclass reaction to fire classification of A2-s1,d0.
- BBA approved – Certificate 21/5878.
- Solutions to meet all BB93 (education) and HTM08-01 (healthcare) acoustic requirements.
- Acoustic solutions may provide opportunity for additional BREEAM points.
- Can be recycled and reprocessed through our Rockcycle® programme<sup>1</sup>, helping to reduce construction waste sent to landfill.

<sup>1</sup>[rockwool.com/uk/about-us/sustainability/recycling](https://rockwool.com/uk/about-us/sustainability/recycling)

<sup>2</sup> *Airborne Sound Reduction - DPA Cauberg - Huygen 20151078-03. Rain noise - BRE 241438 L707 - 008. Fire Resistance Classification Report - PCA10677A*

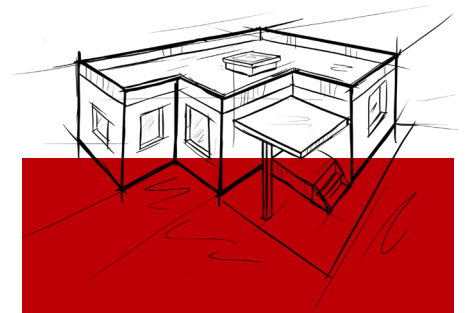

**HardRock Multi-Fix (DD) is a BBA approved insulation board that, in addition to thermal comfort, provides independently tested acoustic and fire resistance properties<sup>2</sup>.**

ROCKWOOL stone wool insulation, like the basalt rock it is made from, is non-combustible with no chemical flame retardants.

# HardRock Multi-Fix (DD)



## APPLICATIONS

HardRock Multi-Fix (DD) can be used with the following roofing systems:\*

- Fully bonded, partially bonded, mechanically fastened single-ply membrane systems, and EPDM membrane systems
- Torch-applied, bitumen-based, and mastic asphalt built up systems
- Liquid-applied systems
- Green roof systems

\*BBA approval subject to use with a waterproofing membrane that has a current BBA Agrément Certificate. For more information, please see Agrément Certificate 21/5878.

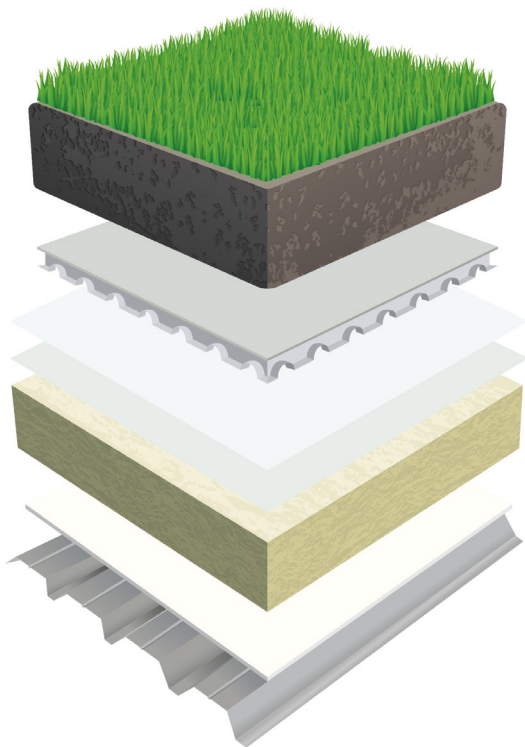

# HardRock Multi-Fix (DD)

## The HardRock Multi-Fix (DD) roofing board range

HardRock Multi-Fix (DD) Underlay Slab	
Application	Primary base layer for all systems
Board size	1200mm x 1000mm
Standard thickness	150mm

HardRock Multi-Fix (DD) Fleece Faced	
Application	Torch-applied, pour and roll bitumen, single-ply and EPDM mechanical or adhered systems, liquid-applied systems and green roof
Board size	1200mm x 1000mm
Standard thicknesses	60mm, 85mm, 105mm, 115mm, 150mm, 185mm

HardRock Multi-Fix (DD) Tapered	
Application	All
Board size	1200mm x 1000mm
Standard thickness	Individually designed to meet scheme requirements

## ROCKWOOL Multi-Fix acoustic flat roof system ancillaries

Acoustic Infills	
Application	Sound-absorbing trough infills for perforated metal decks
Board size	1000mm length shaped to suit all deck profiles

# HardRock Multi-Fix (DD)

## PERFORMANCE

### Thermal performance

The thermal conductivity of HardRock Multi-Fix (DD) roofing boards is 0.039 W/mK ( $\lambda$  90:90).

Typical U-values for metal, concrete, and timber decks based on standard HardRock Multi-Fix (DD) roofing boards thickness range			
U-value (W/m <sup>2</sup> K)	Metal deck no ceiling	150mm reinforced concrete deck no ceiling	22mm timber deck no ceiling
0.25	150mm (single layer)	150mm (single layer)	150mm (single layer)
0.22	170mm (single layer)	170mm (single layer)	170mm (single layer)
0.20	185mm (single layer)	185mm (single layer)	185mm (single layer)
0.18	210mm (150*+60mm)	210mm (150*+60mm)	210mm (150*+60mm)
0.16	235mm (150*+85mm)	235mm (150*+85mm)	235mm (150*+85mm)
0.15	255mm (150*+105mm)	255mm (150*+105mm)	255mm (150*+105mm)

\* The 150mm product is HardRock Multi-Fix (DD) Underlay

### Water resistance and moisture

ROCKWOOL stone wool insulation is water repellent and non-hygroscopic, meaning it will not absorb water from the surrounding environment. It retains its thermal performance even in humid conditions, helping to support the durability of the building fabric.

### Dimensional stability

HardRock Multi-Fix (DD) roofing boards are dimensionally stable when tested to EN 1604 and therefore do not exert any undesirable stress on the fixings or waterproof membrane.

### Fire performance

HardRock Multi-Fix (DD) roof boards have been tested in accordance with EN 1365-2: 2014 and have a fire resistance classification of REI 120 in accordance with EN 13501-2: 2016 (Classification Report - PCA10677A).

### Euroclass classifications

HardRock Multi-Fix (DD) is non-combustible, and achieves a Euroclass reaction to fire classification of A2-s1,d0.

# HardRock Multi-Fix (DD)

## HardRock Multi-Fix (DD) compression table

The tables below are based on **four** pedestals per m<sup>2</sup>. In extrapolating to different arrangements, note that the total load applied should not exceed 500kg/m<sup>2</sup>.

Square		Circular	
Side (mm)	Max weight (kg)	Diameter (mm)	Max weight (kg)
170	70	170	55
200	97	200	76
220	118	220	92
305	125	305	125
455	125	455	125
Maximum load 500kg/m <sup>2</sup>			

The loadings above have been determined through testing and allow for up to 2% deflection within the elastic limit.

## Support load guidance (Support sizes / Maximum load / Number of feet per m<sup>2</sup>)

The tables below are based on the pedestals size, number of pedestals per m<sup>2</sup> required to not exceed the total load of 500kg/m<sup>2</sup>.

Side (mm)	Kg	No. Feet /m <sup>2</sup>
170 x 170	74.8	7
220 x 220	83.7	6
305 x 305	94.8	5
Maximum load 500kg/m <sup>2</sup>		

Diameter (mm)	Kg	No. Feet /m <sup>2</sup>
170	74.8	7
220	80.7	6
305	88.9	5
Maximum load 500kg/m <sup>2</sup>		

## Acoustic performance

ROCKWOOL offers a comprehensive range of tested acoustic solutions for flat roof applications. For further information on acoustic flat roof applications, please refer to the [Flat Roof Acoustic Reference Guide](#).

# HardRock Multi-Fix (DD)

## INSTALLATION

### Single-ply / EPDM roofing

#### Mechanically fastened single-ply/EPDM membrane systems

HardRock Multi-Fix (DD) roofing boards are suitable for mechanically fastened single-ply/EPDM systems.

#### HardRock Multi-Fix (DD) board fixing methods

Where the complete roofing board system is mechanically fastened, it is recommended that a minimum of one mechanical fastener is used centrally per board to secure the boards during installation. The HardRock Multi-Fix roofing boards are to be laid staggered, tightly butt-jointed and mechanically fastened through the vapour control layer to the deck.

#### Mechanical fastener type

ROCKWOOL recommends the use of a plastic tube washer, or stress plate support thread when mechanically fastening roofing boards to metal, concrete or timber decks.

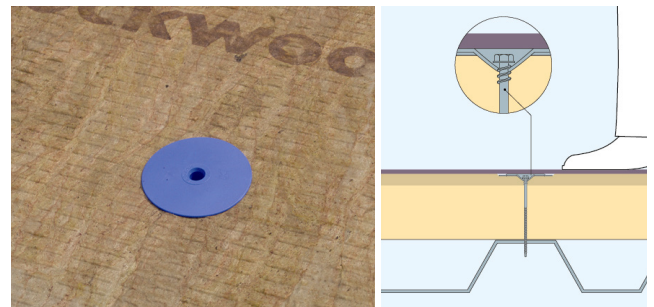
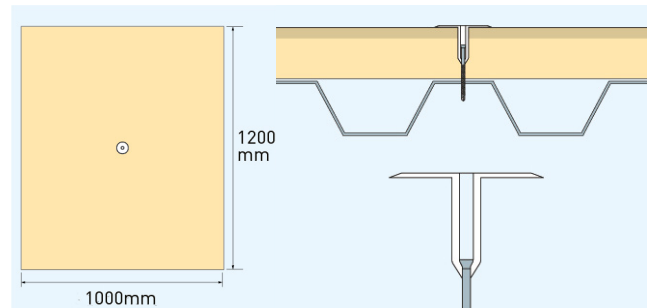

Installed plastic tube and washer

#### Fully/partially adhered single-ply/EPDM membrane systems

HardRock Multi-Fix (DD) roofing boards are to be used with fully or partially adhered single-ply/EPDM membranes. The fleece facing of the board encourages a strong bond between membrane and insulation whilst reducing the amount of adhesive needed. A single-ply/EPDM membrane which has been tested and deemed compatible for bonding to HardRock Multi-Fix (DD) is to be applied to the insulation with the relevant adhesive.

Where the membrane is fully bonded to the insulation surface, the number of mechanical fasteners per board (if required) should be determined by wind loading calculations conducted by the membrane manufacturer.

#### HardRock Multi-Fix (DD) installation

The HardRock Multi-Fix (DD) boards are to be laid strictly in accordance with the manufacturer's recommendations, staggered and tightly butt-jointed, and either fully bonded with an approved adhesive or mechanically fastened through the vapour control layer to the deck. The vapour control layer is to be fixed to the deck in accordance with the manufacturer's recommendations.

#### Membrane installation/fasteners

The single-ply/EPDM membrane should be installed strictly in accordance with the manufacturer's specification and fastening requirements for wind uplift in accordance with the manufacturer's recommendations.



A bonded membrane incorporating HardRock Multi-Fix (DD)

# HardRock Multi-Fix (DD)

## HardRock Multi-Fix (DD) used in the application of an Upstand board

For the application of an upstand board, the HardRock Multi-Fix (DD) board can be cut to size and used on a warm flat roof on a parapet wall. This application provides a non-combustible insulation solution for upstands and parapet walls, with all the performance of the HardRock Multi-Fix (DD) boards.

### Installation

Installation will vary depending on the roof system being installed. For specific guidance please refer to the relevant waterproofing manufacturer.

At a minimum we recommend using three insulation fixings per board, one centrally located and one insulation fixing each side to the top of the board.

When installed, provided that the top surface is protected by a sill or cover and membrane applied, HardRock Multi-Fix (DD) upstand board is suitable for long-term exposure.

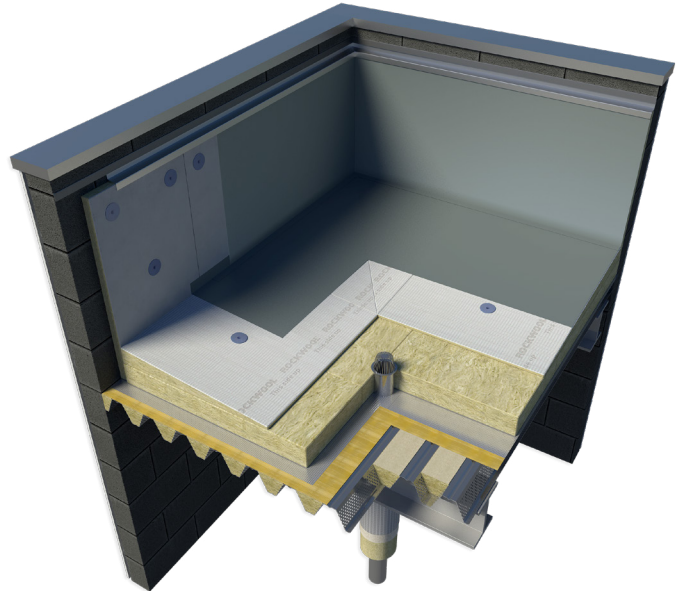

## HardRock Multi-Fix (DD) Roofing boards Design considerations

### Flat roof design

The roof construction and design should comply with BS 6229 (Code of Practice for Flat Roofs with Continuous Supported Coverings).

### Design considerations for profiled metal decks

#### Crown and trough position

HardRock Multi-Fix (DD) roofing boards must be laid with the long edge at right angles to the profiles of the metal deck. Butt joints should occur at the midcrown position, except where cantilevering is applicable.

#### Free spanning capability

For free spanning, the minimum board thickness is equal to the maximum trough width divided by 3. The maximum trough width suitable for free-spanning HardRock Multi-Fix (DD) is 300mm.

Where installed trough widths exceed the maximum spanning capability of the board, provision must be made to provide full support for the insulation. Please refer to Table 4 of the HardRock Multi-Fix (DD) BBA certificate (21/5878) for further details.

#### Cantilevering

- Boards of 60mm or greater thickness may cantilever over a trough.
- For cantilevering the minimum board thickness is equal to the maximum trough width divided by 2.

#### Walkways and access areas

It is an industry recommendation that a supporting layer be placed on the roof both during installation and upon completion in designated walkways or in areas of high foot traffic.

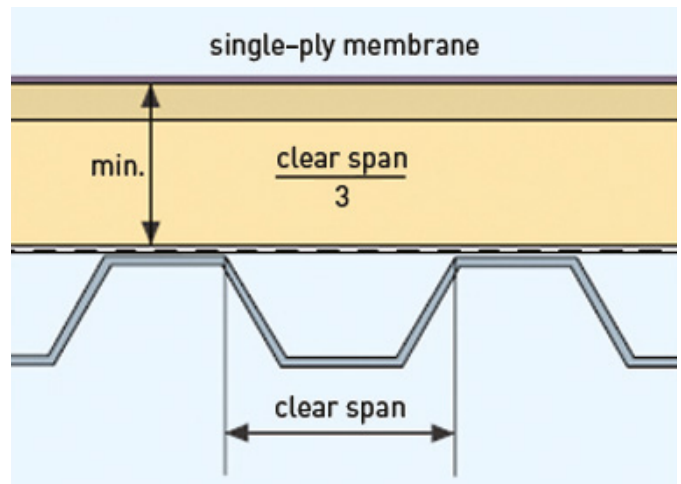

Note that the span to be measured is across the clear width of the trough, and not from the centre to centre of the crowns.



# HardRock Multi-Fix (DD)

Advice should be sought from the membrane manufacturer about available options.

## Additional roof loads: Plant and machinery

- Wherever possible, any roof-mounted plant, such as air handling or refrigeration units, should be positioned on independent upstands bearing directly onto the substrate.
- Where this is not possible, and the equipment is to be placed directly onto the finished roof, further protection may be required to spread the load on the Multi-Fix roofing boards. In such cases advice should be sought from the ROCKWOOL Technical Solutions Team and the membrane manufacturer.

## Preparation work for refurbishment works

- Check that the existing roof finish is sound and watertight.
- Check that the type and condition of the surface is suitable for the bonding or mechanical fixing of HardRock Multi-Fix (DD) roofing boards. If the roof is not sound and watertight or does not have a suitable surface, remove all previously applied finishes and, if necessary, insulation layers.
- It is recommended that the specifier/contractor checks the existing levels to ensure that the falls are sufficient.

# HardRock Multi-Fix (DD)

## Bitumen/Mastic asphalt/Green roof/Liquid membrane

### Built-up bituminous membranes

HardRock Multi-Fix (DD) boards can be used below built-up bitumen roofing (bituminous felt or asphalt).

### HardRock Multi-Fix (DD) installation

For dual-layered systems, place the 150mm HardRock Multi-Fix (DD) Underlay Slab down first and add the fleece-faced Multi-Fix top board with the fleece facing upwards to receive the bitumen.

For single-layer systems, only the fleece-faced Multi-Fix top board is required.

The boards are to be laid staggered, tightly buttjointed and either fully bonded in hot/cold bitumen or mechanically fastened through the vapour control layer to the deck.

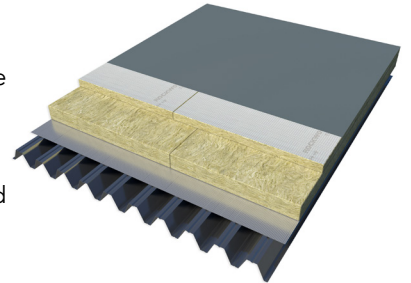

### Torch-applied bituminous membranes

HardRock Multi-Fix (DD) is designed for use with most fully bonded torch-applied multi-layer bituminous systems. When applying the bitumen membrane always torch with minimum heat at all times. Torch the roll of waterproofing felt using appropriate flame/edge guards at all times.

Torch-applied bituminous membranes should always be installed in accordance with the membrane manufacturers' guidelines.



### Liquid applied

Cold liquid-applied membranes offer a seamless watertight finish and are ideal for roof refurbishment, roof details, and roof repairs. HardRock Multi-Fix (DD) can be used with a number of liquid-applied membrane systems. For more information, advice, and guidance on compatible systems please contact the ROCKWOOL Technical Solutions team.

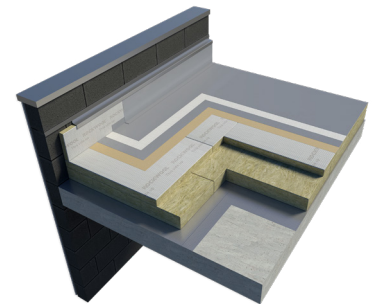

### Green roofs

HardRock Multi-Fix (DD) roofing board is suitable for use in green roof constructions. Where an approved mechanically fixed membrane is being used, HardRock Multi-Fix (DD) boards should be laid in accordance with the roof board installation method described opposite.

Where a fully bonded membrane system is used, the approved membrane must be bonded to HardRock Multi-Fix (DD) in accordance with the membrane manufacturer's instructions. The Multi-Fix boards can be fully bonded or mechanically fastened through the vapour control layer to the deck.



# HardRock Multi-Fix (DD)

## HardRock Multi-Fix (DD) TAPERED ROOFING SYSTEM

The HardRock Multi-Fix (DD) Tapered roofing range is engineered to meet the demand for tapered solutions for new and existing flat roof constructions.

For further information on the HardRock Multi-Fix Tapered range please refer to the following datasheet:

[HardRock Multi-Fix \(DD\) Tapered](#)

# HardRock Multi-Fix (DD)

## HardRock Multi-Fix (DD) FLAT ROOF BOARDS GENERAL OVERVIEW

### Laying and cutting HardRock Multi-Fix (DD)

1. For dual-layer systems, the 150mm Multi-Fix Underlay Slab is applied first, onto the vapour control layer. The Multi-Fix fleece top layer is applied to the underlay with the fleece facing upwards.
2. The HardRock Multi-Fix (DD) roofing boards should be laid with staggered joints and tightly butted to avoid gaps.
3. Ensure that the fleece layer is used on the upper side towards the membrane. This is clearly marked on the boards as 'ROCKWOOL® - this side up'.
4. The boards can be cut to shape using a fine toothed saw or panel saw.
5. Care should be taken to clean off all surfaces prior to the laying of the boards and membrane.
6. Appropriate stop battens should be installed to protect the boards' open edges during installation.
7. Day joints must be formed at the conclusion of each section of work to seal exposed edges and prevent damage.

### Protection of HardRock Multi-Fix (DD) roofing board during installation

Adequate temporary protection must be provided above the installed boards where any of the following occur:

- Unloading or access points
- Temporary walkways
- Stockpiles of roofing materials
- Waste skips
- Any other activity that might cause damage to the insulation

### Working platform

Under no circumstances should the finished roof be used as a working platform without adequate protection being provided.

ROCKWOOL recommends that either the main or roofing contractor operates a 'permit to work' system for any follow-on trades in areas where the roof installation is carried out.

### Handling and storage

HardRock Multi-Fix (DD) roofing boards are fully palletised and wrapped in a polythene shroud for protection during transit and for short-term protection if stored outside.

For longer-term protection, the pallets should be stored under a secure waterproof covering. Boards should be stacked no more than two pallets high for safety.

The use of a pallet fork is recommended where a crane is required to lift pallets to roof level.

# HardRock Multi-Fix (DD)

## ADDITIONAL INFORMATION

### Durability

Tests of our stone wool recovered from old buildings have shown that it retains its performance characteristics – thermal, mechanical, fire resistance – for at least 50 years, and probably longer. A test of a 65-year-old stone wool sample found in 2023 during a renovation of Copenhagen airport showed that these characteristics had not diminished after 65 years.\*

\*Testing done at Danish Technical Institute (DTI) in 2023, "Testing ROCKWOOL insulation from CPH airport hangar 4"

\*[ROCKWOOL Technical Bulletin 4 - Durability](#)

### Condensation

ROCKWOOL stone wool insulation is vapour permeable, reducing the risk of condensation, which can lead to rot, mould, and humidity damage.

## STANDARDS AND APPROVALS

### Certificate

HardRock Multi-Fix (DD) and Tapered have been examined by the BBA and granted certificate 21/5878, for use as a thermal insulation layer and to create or improve falls on limited access concrete, timber, or metal flat roof decks in new or existing domestic and non-domestic buildings.

# HardRock Multi-Fix (DD)

## BUILDING SAFETY AND PRODUCT USE

### LEGAL NOTICES

#### General safety requirements – Building Safety Act 2022

ROCKWOOL Limited is committed to supporting specifiers, resellers, and users of ROCKWOOL products for the full life cycle of the product to comply with the obligations and responsibilities set out in the Building Safety Act 2022. With regard to the general safety requirements of the Act, ROCKWOOL Limited cannot control or foresee every situation where its products might be used. We therefore strongly advise that specifiers, resellers, and users contact us where use of ROCKWOOL products is contemplated in applications different from those explicitly described in the latest, relevant ROCKWOOL product datasheets; especially in applications that can be reasonably foreseen as critical to safety.

ROCKWOOL Limited reserves the right to amend the specification of its products without notice. Changes to the ROCKWOOL manufacturing process, or to pertinent regulations, may be reflected in changes to tested and certified product performance. Whilst ROCKWOOL Limited endeavours to keep its publications up to date, readers will appreciate that between publications there may be pertinent changes in the law or other developments affecting the accuracy of the information contained in our publications.

ROCKWOOL Limited does not accept responsibility for the consequences of using (including testing or certifying) its products in applications different from those explicitly described in the relevant ROCKWOOL product datasheets. Expert advice should be sought, and ROCKWOOL Limited should be contacted, where such different use is contemplated, or where the extent of any use described by ROCKWOOL Limited is in doubt.

#### The ROCKWOOL Trademark

ROCKWOOL® – our trademark

The ROCKWOOL trademark was initially registered in Denmark as a logo mark back in 1936. In 1937, it was accompanied with a word mark registration; a registration which is now extended to more than 60 countries around the world.

The ROCKWOOL trademark is one of the most important assets of the ROCKWOOL Group, and is therefore well-protected and defended by ROCKWOOL throughout the world.

If you require permission to use the ROCKWOOL logo for your business, advertising or promotion, you must apply for a Trade Mark Usage Agreement.

To apply, write to:  
[marketcom@rockwool.com](mailto:marketcom@rockwool.com)

#### Trademarks

Registered trademarks of the ROCKWOOL Group include but are not limited to:

ROCKWOOL®, RockClose®, RainScreen Duo Slab®, HardRock®, RockFloor®, Flexi®, RockFall®, FirePro®, DuctRock®, BeamClad®, NyRock®

© ROCKWOOL 2026.  
All rights reserved.

#### Health and safety

A Material Safety Data Sheet is available and can be downloaded from [rockwool.com/uk](http://rockwool.com/uk) to assist in the preparation of risk assessments, as required by the Control of Substances Hazardous to Health Regulations (COSHH).

#### Photography and illustrations

The product illustrations are the property of ROCKWOOL Limited and have been created for indicative purposes only.

Unless indicated below, the photography and illustrations used in this guide are the property of ROCKWOOL Limited. We reserve all rights to the usage of these images.

If you require permission to use ROCKWOOL images, you must apply for a Usage Agreement.

To apply, write to:  
[marketcom@rockwool.com](mailto:marketcom@rockwool.com)

# HardRock Multi-Fix (DD)

Company:	ROCKWOOL Limited
Version:	Version 2.07 February 2026 (to check this is the latest version, please refer to <a href="https://rockwool.com/uk">rockwool.com/uk</a> )
Revised on:	30.01.2026
Product name:	HardRock Multi-Fix (DD)
Replaces version:	Version 2.06 December 2025
Changes made:	<ul style="list-style-type: none"><li>• Updated certifications</li></ul>
Additional information:	N/A

*Please ensure you are using the latest version of this document by verifying it on our official website. Do not rely on printed or previously downloaded copies, as these may be out of date.*

*Please contact the ROCKWOOL Technical Support Team if you would like to access archived versions of this document.*

# HardRock Multi-Fix (DD)

## ROCKWOOL stone wool – safe to install and live alongside

There are no hazardous classifications associated with stone wool insulation manufactured by ROCKWOOL UK according to EU REACH and UK REACH regulations on health and the environment.

ROCKWOOL safe use instruction sheets and material safety data sheets (where applicable) can be downloaded [here](#).



### Sustainability

ROCKWOOL products are used to help enrich modern living, supporting more resilient and comfortable buildings.

We transform abundant, natural volcanic rock into stone wool insulation products that help our customers tackle energy consumption, noise pollution, fire resilience, and climate change challenges such as water scarcity and flooding.

Since our stone wool is endlessly recyclable with no loss in its performance properties, we can take back clean, uncontaminated new off-cuts, and unused ROCKWOOL stone wool insulation from construction sites in the UK. Our service, Rockcycle®, takes back our stone wool and recycles it back into production where it is used to make new ROCKWOOL products.

Our annual sustainability reports, which set out progress against our sustainability goals and further details of the positive impacts of using our products, can be found on our website.

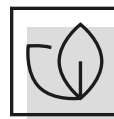

### Environment

ROCKWOOL takes a fact-based, auditable approach to documenting our progress in maximising our products' positive impact and minimising the effect our operations have on the environment, backed by third-party references and methodologies. Further details can be found online in our annual sustainability report.

Our high-tech production process uses filters, pre-heaters, after-burners, and other cleaning and collection systems that help to reduce the effects of our manufacturing operations on the environment.

ROCKWOOL stone wool insulation does not contain (and has never contained) gases that have ozone depletion potential (ODP) or global warming potential (GWP).

