

Application  
Conditions / Limits

Temperature

The use of this PVC is limited to geographical locations with average monthly minimum temperatures of -50°C and maximum temperatures of +50°C. Permanent ambient temperature during use is limited to +50°C.

Installation  
Instructions

Installation Method

According to the valid installation instructions for the S-Scupper PVC, the S-Scupper PVC must be fastened to the roof parapet.

Notes on installation /  
Limits

Installation work must be carried out only by Registered Samelli Contractors.

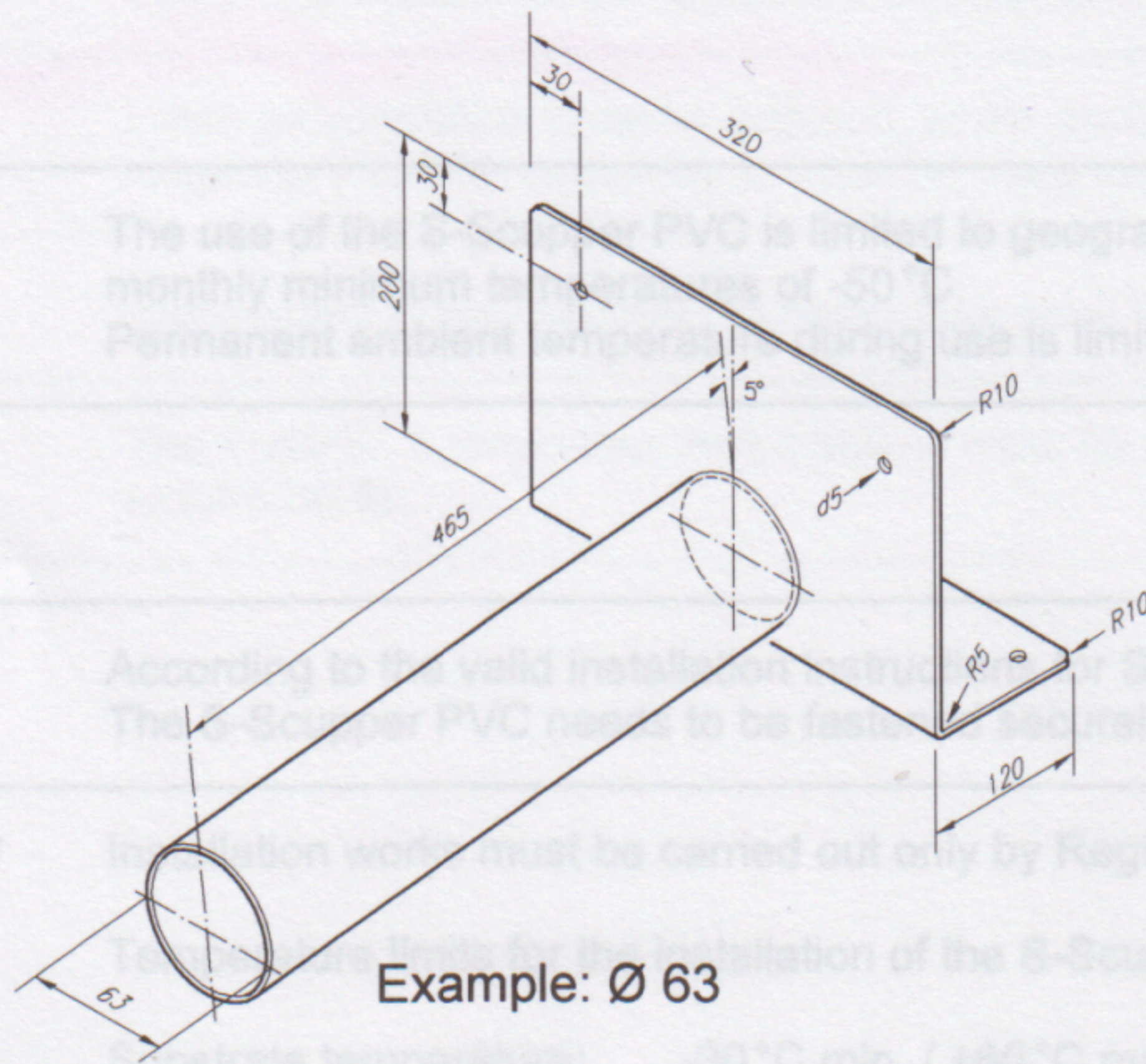

Art. No.	Spigot			Base plate 90° angled	Flow rates
	ø outside	length L	inclination angle α		
111965	40 mm	450 mm	5°	250 mm x 145/105 mm	0.17 l/s
111966	50 mm	450 mm	5°	250 mm x 150/100 mm	0.22 l/s
111967	63 mm	450 mm	5°	320 mm x 200/120 mm	0.28 l/s
111968	75 mm	450 mm	5°	320 mm x 200/120 mm	0.33 l/s
111969	90 mm	450 mm	5°	320 mm x 200/120 mm	0.39 l/s

### Technical Data

**Material Basis** Polyvinyl chloride (PVC)

**Thickness** 4.0 mm

0.0044 l/s/mm