

### Installation Recommendations for Hips

1

Install the underlay and tiling/slating battens as normal ensuring that the ends of the battens are fixed to the hip rafter. A 5mm continuous gap should be maintained either side of the hip rafter if roof ventilation is required at the hip.

2

Install 50mm wide timber hip batten support blocks screwed to the hip rafter between the tiling/slating battens and at the ridge & eaves to support a screw fixed continuous hip batten. Hip batten to be of sufficient height to allow the fixing of the hip tiles with the screws and gaskets provided.

3

Complete the installation of the tiles and slates, cutting them neatly and close to the hip batten or leaving a 5mm ventilation gap if required. Small cuts of interlocking tiles should be secured at the head using tile clips (available separately, code DVC) or other mechanical means. When using double lap tiles or slates, a wider tile or slate should be used to avoid small cuts.

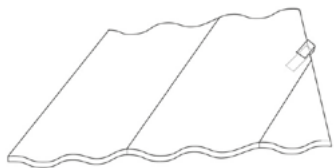

Tile Clip Detail. See step 3

4

Starting from the eaves, the Rollflex membrane should be placed centrally over the hip batten and tacked into position using corrosion resistant nails or staples. Subsequent lengths should be overlapped by 100mm and the Rollflex terminated at the apex of the roof. If Rollflex is also used at the ridge, it should be overlapped by 100mm onto the hip Rollflex and trimmed. If not, a lead saddle should be used at the ridge/hip junction.

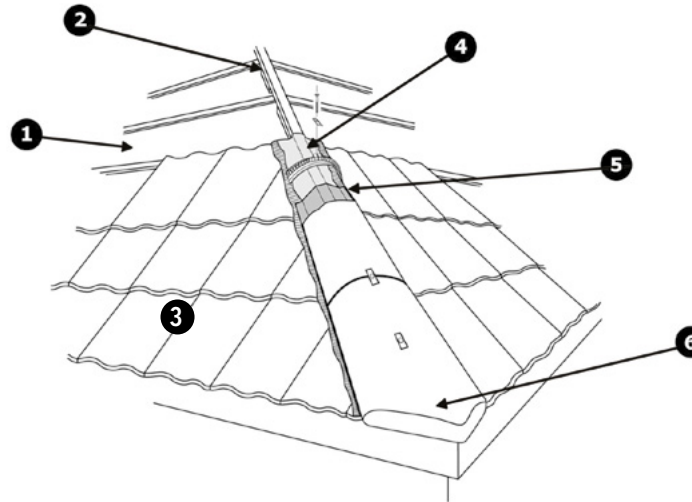

5

Peel off the protective tape from the adhesive strips on the Rollflex and press down firmly onto a clean, dry and dust free tile or slate surface. For profiled tiles, care should be taken to ensure that the Rollflex follows the tile profile closely to provide continuous surface contact.

If using the optional GRP Hip Support Tray (code: HT 165), it should be positioned centrally onto the hip battens and over the Rollflex strip allowing 150mm overly of each length before tacking into position using anti-corrosive nails.

**Note:** The Hip Support Tray is designed for universal use. Most common hip tiles will sit snugly into the outer channels however the product is also designed to carry larger hip tiles on the outer upturned flanges that will deflect downwards. This is not detrimental.

6

Starting at the eaves, drill and fix a block end hip tile into position. Continue to fix the hip tiles centrally along the hip and join using the flexible universal gasket, screw and plate provided by fixing through the GRP tray (if used) and Rollflex into the hip battens ensuring that the hip tiles are butted up tight to the gasket. The gasket ends may be trimmed to the inside profile of the hip tiles where the ends protrude excessively.

7

Once at the ridge, both hip tiles and the ridge tile should be close mitred and drilled to permit screw fixing into the ridge and hip battens with the screws and plates provided. A full length hip tile should be used at the ridge, with any adjustment made by reducing the length of the adjacent hip tiles.

#### Notes:

The Rollflex should be stored at temperatures not exceeding 35°.

It is recommended that the installation of the Rollflex strip be suspended when external temperatures fall below 5°C or exceed 30°C.

The tile or slate surface to be adhered to by the Rollflex strip should be clean and dry and free from dust, debris, grease and other contaminants.

The Rollflex strip should be installed ensuring that the ventilating centre membrane is not stretched and that both the centre membrane and the adhesive strips are not exposed to direct UV solar radiation.

The hip tile edges should sit on corrugated metal edges of the Rollflex strip.

### Installation Recommendations for Ridges

**1**  
Install the underlay and tiling/slating battens as normal. If ventilating the roof space (below the underlay), leave the underlay approximately 30mm short of the apex on both sides.

**2**  
For a trussed rafter roof, fix 50mm wide ridge batten or battens along the centreline of the roof apex using the metal straps provided. They may be nailed to the rafters either above or below the underlay. If a ridge board exists, it may be necessary to build up the height using battens that should be secured to either the rafters or ridge board using the metal straps.

**3**  
Fix the top tiling/slating battens and complete the tiling or slating in the usual manner ensuring that a ventilation gap is maintained where required.

**4**  
Lay the Rollflex strip centrally along the ridge batten and tack into position using corrosion resistant nails or staples. Subsequent lengths should be overlapped by 100mm. At the gable end, the Rollflex should be trimmed down the face of the verge for a cloaked or dry fix application, or trimmed back by appropriately 50mm where a bedded verge is used.

**5**  
Peel off the protective tape from the adhesive strips on the Rollflex and press down firmly onto a clean, dry and dust free tile or slate surface. For profiled tiles, care should be taken to ensure that the Rollflex follows the tile profile closely to provide continuous surface contact.

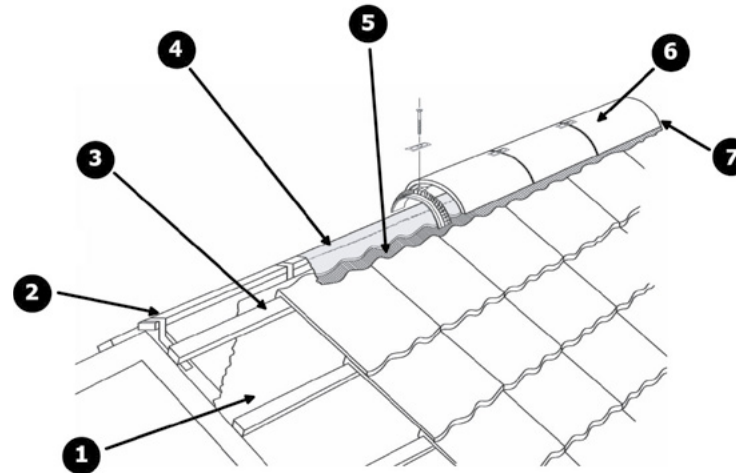

We offer the following range of ridge and hip fixing kits for the CON6+:  
**Supplementary Tile Fixing, code DFRK/1X**  
**Ridge and Hip End Fixing, code LK/3X**  
**Mortar Bedded Fixing, code LK/4X**  
 To find out more, visit our website.

**6**  
Place the ridge tiles centrally along the ridge and join using the flexible universal gasket, screw and plate provided by fixing through the Rollflex and into the ridge battens ensuring that the ridges are butted up tight to the gasket. The gasket ends may be trimmed where the ends protrude excessively when using smaller ridge tile types.

**7**  
At the ends of the ridge, whether using a block-end ridge or ridge end cap, the last ridge tile should be drilled in the conventional manner and an additional screw and plate used to secure the tile to the ridge battens.

**Notes:**  
 The Rollflex should be stored at temperatures not exceeding 35°.

It is recommended that the installation of the Rollflex strip be suspended when external temperatures fall below 5°C or exceed 30°C.

The tile or slate surface to be adhered to by the Rollflex strip should be clean and dry and free from dust, debris, grease and other contaminants.

The Rollflex strip should be installed ensuring that the ventilating centre membrane is not stretched and that both the centre membrane and the adhesive strips are not exposed to direct UV solar radiation.

The ridge tile edges should sit on corrugated metal edges of the Rollflex strip and not be over-tightened crushing the corrugations.

CHECK OUT OUR INSTALLATION VIDEO ON 