

G1 Slate Ventilator

# G RANGE TILE & SLATE VENTILATORS

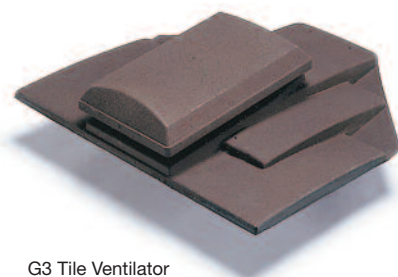

G3 Tile Ventilator

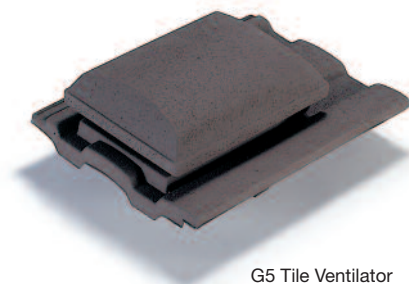

G5 Tile Ventilator







**G**lidevale profile dedicated G range tile and slate ventilators are designed to ventilate through the roof slope and form an integral part of the roof covering.

The tile and slate ventilators can be used at low level or high level where the roof construction does not allow eaves or ridge ventilators to be used, such as where compartment walls or fire break walls obstruct airflow. They are particularly suitable for insulation upgrades when the roof covering is not being changed and recommended by the Energy Efficiency Partnership for Buildings as the solution for ensuring adequate ventilation is provided. They are also used in complex roof shapes where effective cross-ventilation is not possible.

The range of ventilators can also be used as soil vent pipe or mechanical extract terminals with separately supplied accessories.

## BENEFITS

- Profile matched and colour blended in with adjacent slates, tiles and ridges as standard, making the ventilators blend into the roofscape
- Can be installed wherever they are required as part of the normal roofing process.
- Driving rain and deluge rain resistance demonstrated by test data.
- High nett free ventilation area and low airflow resistance allow for an optimum spacing to avoid stagnant air pockets.
- Separately supplied extension sleeves ensure a clear air path from the roof void to the outside to meet the design requirements of BS 5250.
- Integral 4mm large insect ingress screen.
- AA fire rating to BS 476: Part 3: 2004.
- An unrivalled range of slate and tile profiles plus a colour matching service.
- Designed and developed under BS EN ISO 9001.



### Composition, Manufacture

Manufactured from ABS and polypropylene material for a high quality finish and robust construction. All exposed surfaces are coated with a durable water based colour blended surface treatment. This surface treatment has been used on **all** Glidevale Ventilators for over 20 years, and after this time shows only a marginal lightening of shade which is usually counteracted by the effect of atmospheric pollution on the roof covering itself. All tile and ridge ventilators have silica sand entrained in the multi coat coating. Slate ventilators have a smooth finish.



## G RANGE TILE & SLATE VENTILATORS

### Appearance

The ventilators match the roof tiles or slates in size, shape and colour, and all types are available for tiles or slates. See table for full range of standard profiles. Tile and ridge ventilators have silica sand entrained in a multi-coat water based environmentally friendly uv-resistant coating, to help weather more closely with the surrounding tiles over time. Slate ventilators have a smooth finish.

### Roof pitch

G Range Tile and Slate Ventilators are suitable for roof pitches between 20° and 60°. For other pitches consult our Technical Department.

### Underlay Opening Protector

Supplied with G Range tile and slate ventilators to maintain the function of the underlay where it is cut to allow for the Universal Extension Sleeve. Any moisture that may penetrate the roof covering higher up the slope and run down the underlay is safely diverted round the opening, in compliance with BS 5250.



### Universal Extension Sleeve

Should always be used with G Range tile and slate ventilators. It ensures that the roof underlay is cut and that there is a continuous permanent weatherproof path from the roof void to the outside without impairing the weatherproof function of the structure, in accordance with BS 5250. Supplied separately and snap-fits to the underside of the ventilator on site before the ventilator is installed.



### G1 Slate Ventilator



### G3 Slate Ventilator

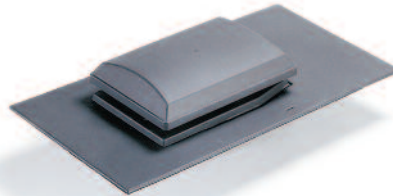

### G5 Slate Ventilator

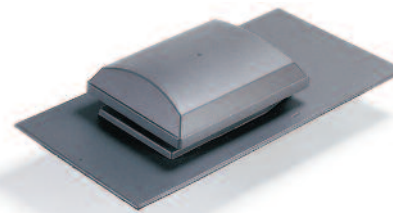

### G1 Tile Ventilator

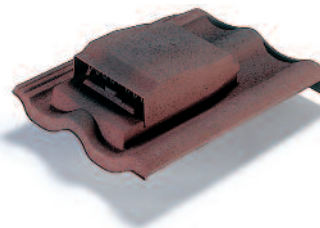

### G3 Tile Ventilator

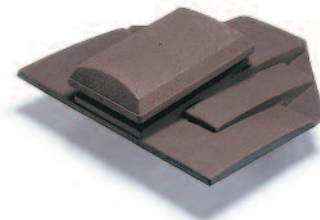

### G5 Tile Ventilator

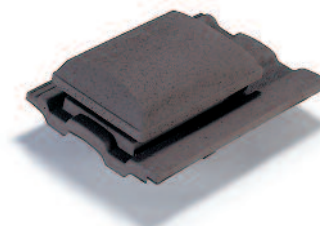

### Specification clauses

Ventilation of roof space  
Provide low level/high level roof space ventilation by means of Glidevale G1/G3/G5 Tile/Slate Ventilators with integral 4mm large insect screen and AA fire rating to BS 476: Part 3: 2004. Size/profile .....colour ..... (matched to tiles/slates), and to be installed complete with Glidevale Extension Sleeves and Underlay Opening Protectors. Install at ..... m centres as shown on drawings to provide ventilation area equivalent to.... mm<sup>2</sup>/m in accordance with Building Regulations Approved Document C2 2004 amd 2010 & 2013 and BS 5250: 2011. Fix in accordance with manufacturer's instructions.

### SVP/mechanical extract terminals

Soil vent pipe stacks/  
Mechanical extract ventilation ducts to be terminated at the roof slope by means of Glidevale G1/G3/G5 Tile/Slate Ventilators, with integral 4mm large insect screen and condensate grooves, and AA fire rating to BS 476: Part 3:2004. Size/profile..... colour .....(matched to tiles/slates), to be installed complete with Glidevale Underlay Opening Protector, GV110 Soil Universal Pipe Adaptor and Flexi Pipe. Install where shown on drawings and fix in accordance with manufacturer's instructions. All joints and connections to be airtight in accordance with Building Regulations Approved Document H, and all pipes and ducts in the roof space to be insulated.



# glidevale

## G1 Tile and Slate Ventilator

The low-profile traditional cowl design projects only 69mm above the roof surface.

### Performance

Guaranteed actual nett free ventilation area: 5000mm<sup>2</sup>

Spacing to achieve:

5000mm<sup>2</sup>/m; 1.0m

10 000mm<sup>2</sup>/m; 0.5m

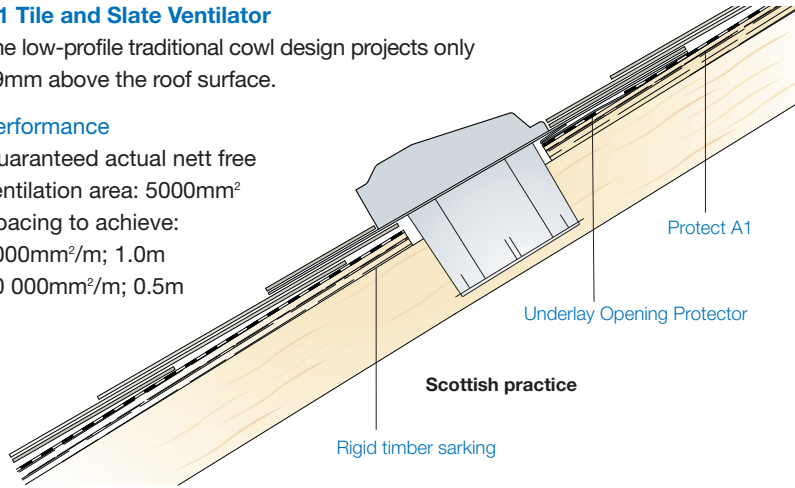

## Soil vent pipe/mechanical extract

G Range ventilators can be used as terminals for soil vent stacks or mechanical extract ventilation ducts. Condensation grooves prevent any condensate running back down the duct. Not suitable for boiler flues.

## Glidevale GV110 Pipe Adaptor

Supplied separately, snap-fits to the Ventilator and connects to Glidevale Flexi Pipe to ensure an airtight connection complying with Building Regulations Approved Document H.



## G3 Tile and Slate Ventilator

The low-profile cowl mirrors the popular G5 on a smaller scale, enabling use at high level in conjunction with G5 ventilators at low level.

### Performance

Guaranteed actual nett free ventilation area: 10 000mm<sup>2</sup>

Spacing to achieve:

5000mm<sup>2</sup>/m; 2.0m

10 000mm<sup>2</sup>/m; 1.0m

25 000mm<sup>2</sup>/m; 0.4m

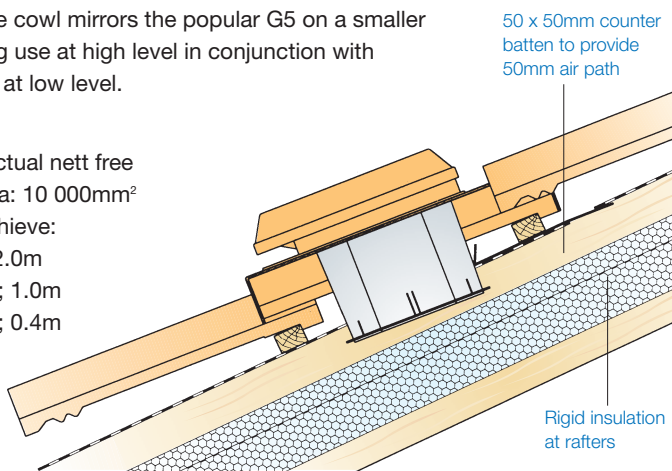

### Performance

Airflow resistance when used as SVP/extract terminals

|                                    | G1    | G3     | G5     |
|------------------------------------|-------|--------|--------|
| 54m <sup>3</sup> /h (15 ltrs/sec)  | 18Pa  | 3.4Pa  | 0.6Pa  |
| 108m <sup>3</sup> /h (30 ltrs/sec) | 70Pa  | 11.5Pa | 2.7Pa  |
| 216m <sup>3</sup> /h (60 ltrs/sec) | 262Pa | 42Pa   | 11.4Pa |

## G5 Tile and Slate Ventilator

The low-profile cowl is geometrically the smallest available in the marketplace for the air capacity, projecting only 85mm above the roof surface.

### Performance

Guaranteed actual nett free ventilation area: 20 000mm<sup>2</sup>

Spacing to achieve:

10 000mm<sup>2</sup>/m; 2.0m

25 000mm<sup>2</sup>/m; 0.8m

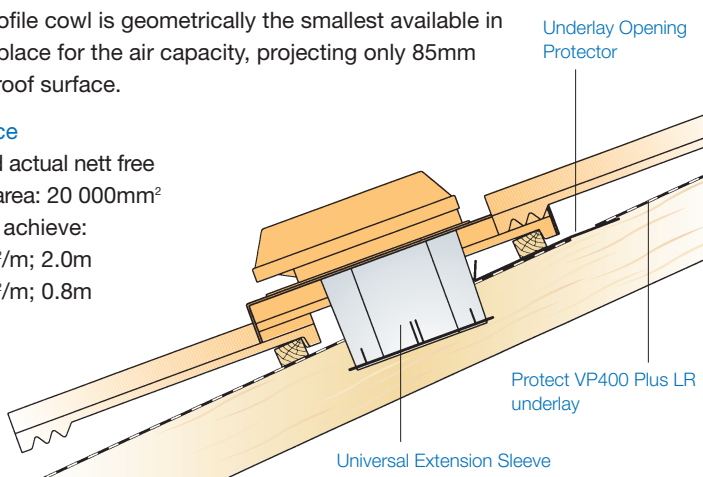

# FLAT ROOF VENTILATION TERMINALS

## Description, Applications

Glidevale Flat Roof Terminals act as outlets for soil vent pipes, passive ventilation stacks or mechanical extract ventilation ducts.

There are options for installation directly on the roof deck with integral prefabricated upstand or for installation on a builder's kerb. They can be used for warm or cold deck roofs with built-up roofing (single or multi-ply); with builder's kerb they can be used with fully-supported metal roofing. The prefabricated upstand provides minimum 150mm clear upstand.

Terminals have a 4mm large insect grille, and condensation grooves which prevent condensate running back down the duct.

## Authority

Terminals are designed and manufactured to BS EN ISO 9001 and can be used to comply with the requirements of Approved Document C2, BS 5250, BS 5720 and BS 6229.

## Material, Colour

Cowl: ABS, upstand aluminium. Slate grey as standard, or colour matched to roof covering.

## Performance

Low resistance to airflow, see table. Also available as a ventilation unit without spigot, MT5U or MT5K, nett free ventilation area 20,000mm<sup>2</sup>. Deluge and driving rain resistant as demonstrated by test.

## Airflow performance

| Type                   | Spigot diam. | Airflow                            | Resistance |
|------------------------|--------------|------------------------------------|------------|
| MT9U/100 or MT9K/100   | 100mm        | 54m <sup>3</sup> /h (15ltrs/sec)   | 0.6Pa      |
|                        |              | 108m <sup>3</sup> /h (30ltrs/sec)  | 2.7Pa      |
|                        |              | 216m <sup>3</sup> /h (60ltrs/sec)  | 11.4Pa     |
| MT9U/125 or MT9K/125   | 125mm        | 54m <sup>3</sup> /h (15ltrs/sec)   | 1.2Pa      |
|                        |              | 108m <sup>3</sup> /h (30ltrs/sec)  | 4.8Pa      |
|                        |              | 216m <sup>3</sup> /h (60ltrs/sec)  | 19.6Pa     |
| MT13U/150 or MT13K/150 | 150mm        | 54m <sup>3</sup> /h (15ltrs/sec)   | 0.32Pa     |
|                        |              | 108m <sup>3</sup> /h (30ltrs/sec)  | 1.22Pa     |
|                        |              | 216m <sup>3</sup> /h (60ltrs/sec)  | 4.86Pa     |
|                        |              | 300m <sup>3</sup> /h (84ltrs/sec)  | 9.50Pa     |
|                        |              | 500m <sup>3</sup> /h (139ltrs/sec) | 27.37Pa    |

Suffix U = integral upstand, K = for builder's kerb

## MT13U Terminal with integral upstand

(MT9U dimensions are the same; only cowl profile differs)  
(MT5U dimensions are the same; supplied without spigot)

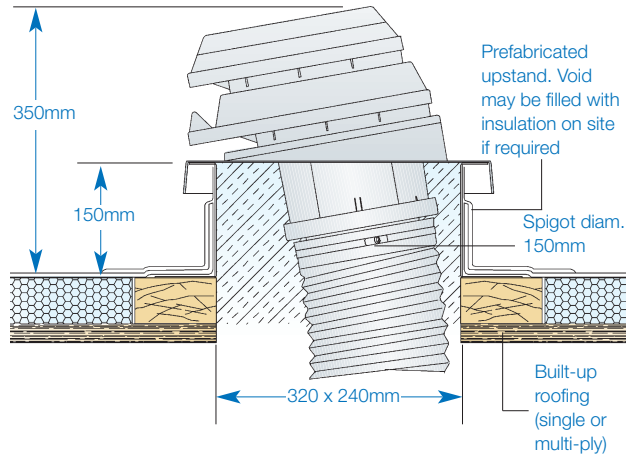

## MT9K Terminal on builder's kerb

(MT13K dimensions are the same; only cowl profile differs)  
(MT5K dimensions are the same; supplied without spigot)

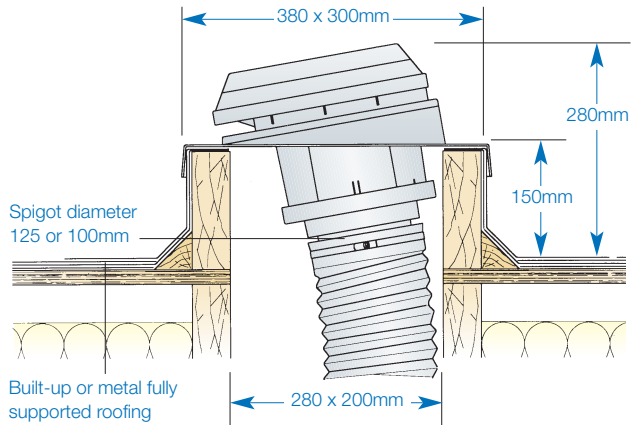

**Specification clause**  
Delete items not required  
Soil vent pipe/ Passive ventilation stack/  
Mechanical extraction ducts to be terminated with Glidevale Flat Roof Terminals MT9U/ MT13U/ MT9K/ MT13K, designed and manufactured under BS EN ISO 9001, and having integral 4mm large insect grille and condensate grooves. Colour: slate grey/ to match roof covering.  
Install on roof deck with integral upstand/ on suitable builder's kerb as shown on drawings, fixed in accordance with manufacturer's instructions. All joints to ductwork to be sealed and mechanically secured.



## STANDARD PROFILES

### Aggregate Industries

Cotswold Slate 500 x 300

### Anchor (Forticrete Roofing Products)

Anchorite Slate\*

Bold Roll

Centurion/Senator\*

Gemini

Plain\*

Stone Slate

Vanguard 83

Viscount

Mini slate

Gemini Mk II

### Ballymena

Montague Plain\*

Penrose Mk I

Penrose Mk II

Pollock Double Roman

### Condron

Double Pantile

Flat

'M' Profile

### Dreadnought

Plain\*

### Eternit Clay Tiles

Plain\*

### Hardrow (Forticrete Roofing Products)

686 x 457

457 x 457

457 x 305

### Hawkins (Eternit Clay Tiles)

Plain\*

### Lagan Tile

Double Roman

Flat

### Langley of London

Coutraï\*

Plain\*

Sterreberg\*

### Marley Building Materials

Anglia\*

Ashmore

Barnstaple

Bold Roll

Domino

Double Roman

Edgemere

Ludlow Major

Ludlow Plus

Malvern

Marlden\*

Marquess\*

Mendip

Modern

Monarch\*

Plain\*

Wessex

Westwold\*

### McLoughlin

Foyletile

Moyslate

### Morrissey

Milford

Rockford

### Sean Quinn

Carnmore

Devenish

Locherne

Western Slate

### Redland

Caledonian

Cambrian\*

Delta

Double Roman

Downland\*

Duo Plain

Essex

Grovebury

Heathland\*

Mini Stonewold

Norfolk Pantile\*

Plain\*

Redland 49

Redland 50/Bridgewater

Redland 51

Redland 52

Regent

Renown

Richmond

Saxon

Statesman

Stonewold Mk II

Landmark Double Pantile

### Roadstone

Cambrian

Double Roman

Flat (Old Stonewold)

Mini Slate

Plain\*

SL8

Spanish Roll

Slate Tile (Cork

Stonewold)

### Rosemary (Redland)

Plain\*

### Russell

Argyll

Cheviot

Derwent

Double Roman

Galloway

Grampian

Pennine

Plain\*

### Sandtoft/Goxhill

20/20

Barrow Bold Roman\*

Bold Roll

Bridgwater

Britlock\*

Calderdale

County Pantile\*

Danum

Double Pantile

Double Roman

Europa

Flemish

Gaelic\*

Greenwood Pantile\*

Humber Plain\*

Lincswold

Lindum

Mercian

Neo Pantile

Old English Pantile\*

Pennine 480 x 280

Plain\*

Shire Pantile

Standard Pattern

Olympus

Rivus

### Scotcem

Forth

Pentland

### Northstone (Scott Toomebridge)

Derrie Mk 1 and Mk 2

Galloway

Plain\*

Seville

Slemish Mk 2

Villa Mk 1 and Mk 2

Donard Mk 2

Tudor

Plain\*

### Redbank (Weatherwell)

Aston

Statesman

Bold Roll

Bretton

Conway

Daniel Platt Plain

Regal

### Slates

600 x 300

500 x 250

400 x 200\*

600 x 335 soaker style

600 x 450 soaker style

\*These tiles require multiple baseplates to ensure a weatherproof installation.

Ventilators designed to suit the tile manufacturers profiles listed here are available in each manufacturer's range of colours. For other profiles and colours please contact our Technical Department.

Company names and product descriptions are the registered trade marks of the relevant manufacturer.

### Composition and manufacture

All Glidevale G Range ventilators are manufactured from upvc, polypropylene or ABS for a consistently high quality finish and long lasting construction. With excellent weathering characteristics Glidevale ventilators will complement any roof for many years to come.

### Building Regulations

All Glidevale G Range ventilators can be used to comply with:

#### Roofspace ventilation:

Building Regulations Approved Document C, BS 5250 and BS 5534.

#### Soil vent pipes:

Building Regulations Approved Document H.

#### Mechanical ventilator terminal:

Building Regulations Approved Document F.

Glidevale's G Range tile and slate ventilators are at the core of an unrivalled capability. Whether you want to cover the widest number of applications with the fewest number of references or you need to match the exact profile and colour for a heritage project Glidevale have the solution. Glidevale is the 'one stop shop' for roof ventilation solutions.

Stockist's stamp

### GLIDEVALE LIMITED

2 Brooklands Road, Sale, Cheshire M33 3SS

Tel: 0161 905 5700 Fax: 0161 905 2085

Email: info@glidevale.com Web: www.glidevale.com

Glidevale Limited maintains a policy of continuous development and reserves the right to amend product specifications without notice.



A division of Building Product Design Ltd. Company Registration No; 3944123

