

Freefoam Plastics Limited

Central Commercial Park
Centre Park Road
Cork
Ireland

Tel: 00 353 21 4966 311 Fax: 00 353 21 4965 273

e-mail: marketing@freefoam.com

website: www.freefoam.com



Agrément Certificate

99/3585

Product Sheet 1

FREEFOAM PLASTICS LIMITED ROOF TRIM SYSTEMS

FREEFOAM WHITE PVC-U ROOF TRIM SYSTEM

This Agrément Certificate Product Sheet⁽¹⁾ relates to the Freefoam White PVC-U Roof Trim System, comprising fascia, soffit and barge boards, soffit ventilator and accessories for external use at the roofline, as a substitute for timber or other conventional materials.

(1) Hereinafter referred to as 'Certificate'.

CERTIFICATION INCLUDES:

- factors relating to compliance with Building Regulations where applicable
- factors relating to additional non-regulatory information where applicable
- independently verified technical specification
- assessment criteria and technical investigations
- design considerations
- installation guidance
- regular surveillance of production
- formal three-yearly review.



KEY FACTORS ASSESSED

Ventilation — the ventilated soffit board can contribute towards providing the necessary roof space ventilation (see section 4).

Strength and stability — in terms of wind loading resistance, the system can be used in all areas of the UK (see section 6).

Performance in relation to fire — when tested in accordance with BS 476-7 : 1997, the cellular boards achieved a Class 1Y surface spread of flame rating and the rigid hollow soffit boards achieved a surface spread of flame rating of Class 2Y (see section 7).

Durability — the system will retain its decorative qualities for a period in excess of 20 years, with only minor changes in surface appearance (see section 9).



The BBA has awarded this Certificate to the company named above for the system described herein. This system has been assessed by the BBA as being fit for its intended use provided it is installed, used and maintained as set out in this Certificate.

On behalf of the British Board of Agrément

Date of Second issue: 18 April 2018

John Albon – Head of Approvals
Construction Products

Claire Curtis-Thomas
Chief Executive

Originally certificated on 8 March 1999

The BBA is a UKAS accredited certification body – Number 113.

The schedule of the current scope of accreditation for product certification is available in pdf format via the UKAS link on the BBA website at www.bbacerts.co.uk
Readers are advised to check the validity and latest issue number of this Agrément Certificate by either referring to the BBA website or contacting the BBA direct.

British Board of Agrément

Bucknalls Lane
Watford
Herts WD25 9BA

©2018

tel: 01923 665300
clientservices@bbacerts.co.uk
www.bbacerts.co.uk

Regulations

In the opinion of the BBA, the Freefoam White PVC-U Roof Trim System, if installed, used and maintained in accordance with this Certificate, can satisfy or contribute to satisfying the relevant requirements of the following Building Regulations (the presence of a UK map indicates that the subject is related to the Building Regulations in the region or regions of the UK depicted):



The Building Regulations 2010 (England and Wales) (as amended)

Requirement:	A1	Loading
Comment:		The system can sustain and transmit wind loads to the substrate. See section 6.1 of this Certificate.
Requirement:	C2(b)	Resistance to moisture
Comment:		The system will contribute to providing protection. See section 4.1 of this Certificate.
Requirement:	C2(c)	Resistance to moisture
Comment:		The ventilation components of the system can contribute to enabling a roof to satisfy this Requirement. See sections 4.4 to 4.11 of this Certificate.
Regulation:	7	Materials and workmanship
Comment:		The components of the system are acceptable. See section 9.1 and the <i>Installation</i> part of this Certificate.



The Building (Scotland) Regulations 2004 (as amended)

Regulation:	8(1)(2)	Durability, workmanship and fitness of materials
Comment:		The system is acceptable. See sections 8.1 to 8.3 and 9.1 and the <i>Installation</i> part of this Certificate.
Regulation:	9	Building standards applicable to construction
Standard:	1.1	Structure
Comment:		The system can sustain and transmit wind loads to the substrate. See section 6.1 of this Certificate.
Standard:	3.10	Precipitation
Comment:		The system will contribute to satisfying this Standard. See section 4.1 of this Certificate.
Standard:	3.15	Condensation
Comment:		The ventilation components can contribute to enabling a roof to satisfy this Standard, with reference to clauses 3.15.1 ⁽¹⁾ , 3.15.3 ⁽¹⁾ , 3.15.5 ⁽¹⁾ and 3.15.7 ⁽¹⁾ . See sections 4.4 to 4.11 of this Certificate.
Standard:	7.1(a)	Statement of sustainability
Comment:		The system can contribute to meeting the relevant requirements of Regulation 9, Standards 1 to 6, and therefore will contribute to a construction meeting a bronze level of sustainability as defined in this Standard.
Regulation:	12	Building standards applicable to conversions
Comment:		All comments given for this system under Regulation 9, Standards 1 to 6, also apply to this Regulation, with reference to clause 0.12.1 ⁽¹⁾⁽²⁾ and Schedule 6 ⁽¹⁾⁽²⁾ .

(1) Technical Handbook (Domestic).

(2) Technical Handbook (Non-Domestic).



The Building Regulations (Northern Ireland) 2012 (as amended)

Regulation:	23	Fitness of materials and workmanship
Comment:		The system is acceptable. See section 9.1 and the <i>installation</i> part of this certificate.
Regulation:	28(b)	Resistance to moisture and weather
Comment:		The system will contribute to providing protection. See section 4.1 of this Certificate.
Regulation:	29(b)	Condensation
Comment:		The ventilation components of the system can contribute to enabling a roof to satisfy this Regulation. See sections 4.4 to 4.11 of this Certificate.
Regulation:	30	Stability
Comment:		The system can sustain and transmit wind loads to the substrate. See section 6.1 of this Certificate.

Construction (Design and Management) Regulations 2015

Construction (Design and Management) Regulations (Northern Ireland) 2016

Information in this Certificate may assist the client, designer (including Principal Designer) and contractor (including Principal Contractor) to address their obligations under these Regulations.

See section: 11 *General* (11.7 and 11.9) of this Certificate.

Additional Information

NHBC Standards 2018

In the opinion of the BBA, the Freefoam White PVC-U Roof Trim System, if installed, used and maintained in accordance with this Certificate, can satisfy or contribute to satisfying the relevant requirements in relation to *NHBC Standards*, Chapter 7.2 *Pitched roofs*.

Technical Specification

1 Description

1.1 The Freefoam White PVC-U Roof Trim System is for external use on roofs as a substitute for timber or other conventional materials.

1.2 The system comprises a range of cellular PVC-U (PVC-UE) boards, which are shown in Figure 1. Ancillary components, including a rigid soffit ventilator, rigid hollow soffits and other extruded trims, and injection moulded joints and end caps, are shown in Figure 2.

Figure 1 Fascia/barge boards

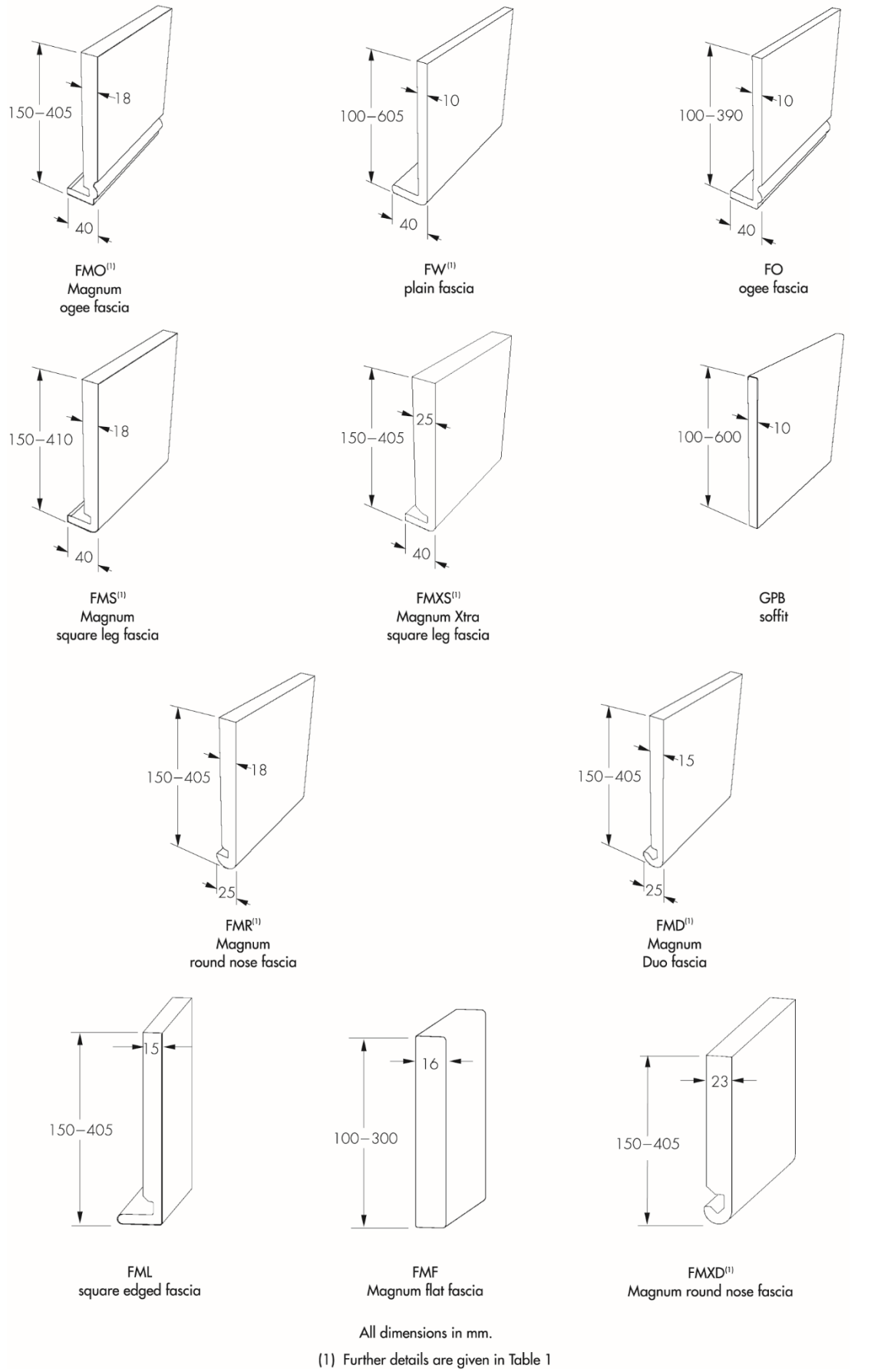
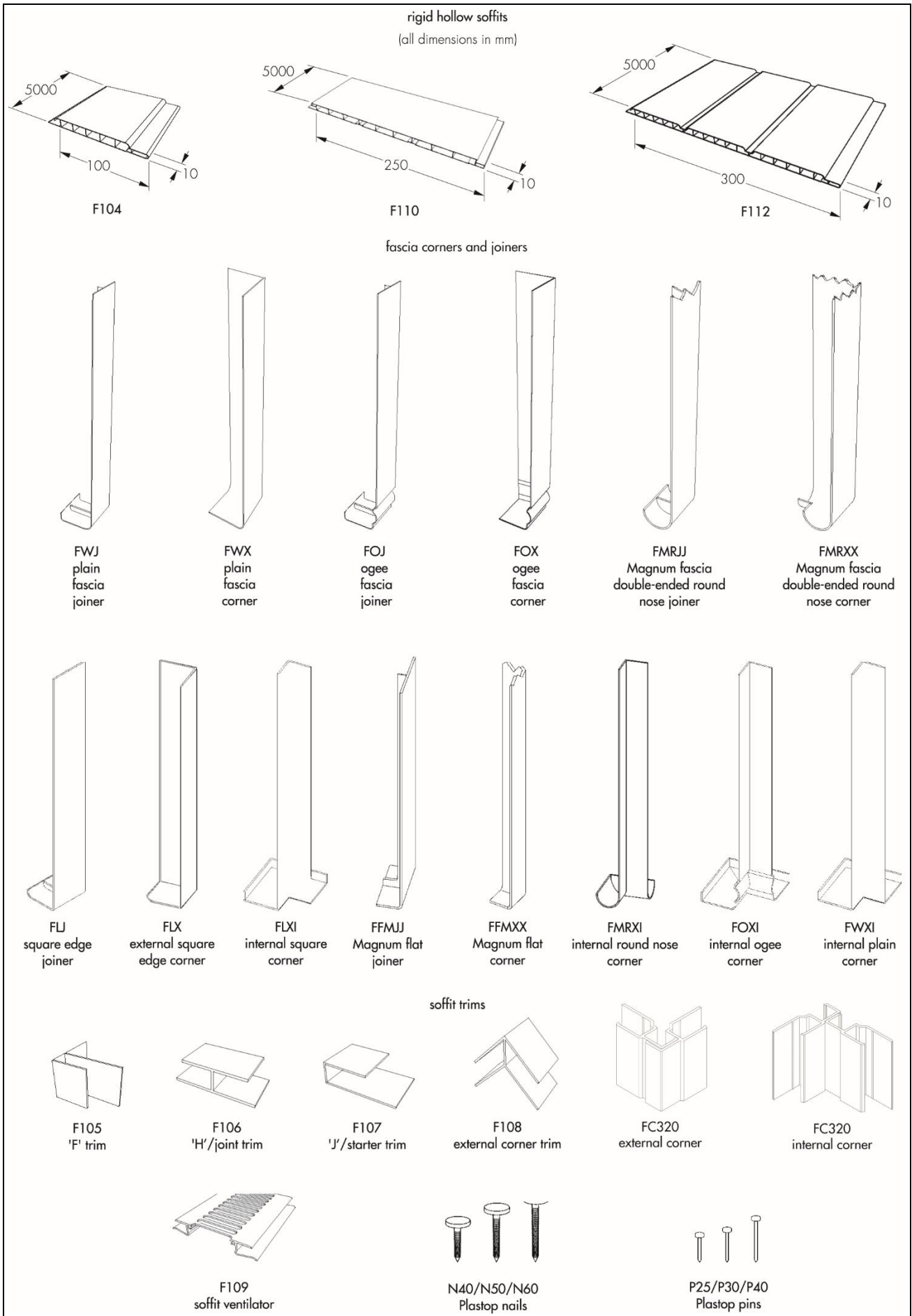

Figure 2 Ancillary components



1.3 Characteristics of the cellular boards are shown in Table 1, and compatibility with ancillary components in Table 2.

Table 1 Characteristics of boards

	Standard length (m)	Width (mm)	Nominal thickness (mm)	Minimum thickness of outer skin (mm)	Average density (kg·m ⁻³)
FW Plain fascia	5	100, 125, 150 175, 200, 225, 250, 300, 400, 410 ⁽¹⁾ (F410P), 450, 605 ⁽¹⁾ (F605P)	10	0.4	0.48
FO Ogee fascia	5	100, 150, 175, 200, 225, 250, 300, 390	10	0.4	0.48
FMS Magnum square leg fascia	5	150, 175, 200, 225, 250, 300, 410 ⁽¹⁾	18	0.4	0.48
GPB Soffit board	5	100, 125, 150, 175, 200, 225, 250, 300, 350, 400 (GPB405), 450, 500, 600 (GPB605)	10	0.4	0.48
FMXS Magnum Xtra square leg fascia	5	150, 175, 200, 225, 250, 405 ⁽¹⁾	25	0.4	0.48
FMR Magnum round nose fascia	5	150, 175, 200, 225, 250, 405 ⁽¹⁾	18	0.4	0.48
FMD Magnum duo fascia	5	150, 175, 200, 225, 250, 405 ⁽¹⁾	15	0.4	0.48
FMO Magnum ogee fascia	5	150, 175, 200, 225, 250, 405 ⁽¹⁾	18	0.4	0.48
FMXD Magnum round nose fascia	5	150, 175, 200, 225, 250, 300, 405 ⁽¹⁾	23	0.4	0.48
FMF Magnum flat fascia	5	100, 125, 150, 175, 200, 250, 300	16	0.4	0.48
FML Square edged fascia	5	150, 175, 200, 225, 250, 405 ⁽¹⁾	15	0.4	0.48

(1) Double-ended board.

Table 2 Ancillary component and board compatibility

	FW	FO	FMS	FMXS	FMR	FMD	FMO	FMXD	FMF	FML
FWJ	✓	—	✓	✓	—	—	—	—	—	—
FWX	✓	—	✓	✓	—	—	—	—	—	—
FWXI	✓	—	✓	✓	—	—	—	—	—	—
FOJ	—	✓	—	—	—	—	✓	—	—	—
FOX	—	✓	—	—	—	—	✓	—	—	—
FOXI	—	✓	—	—	—	—	✓	—	—	—
FMRJJ	—	—	—	—	✓	✓	—	✓	—	—
FMRXX	—	—	—	—	✓	✓	—	✓	—	—
FMRXI	—	—	—	—	✓	✓	—	✓	—	—
FLJ	—	—	—	—	—	—	—	—	—	✓
FLX	—	—	—	—	—	—	—	—	—	✓
FLXI	—	—	—	—	—	—	—	—	—	✓
FFMJJ	—	—	—	—	—	—	—	—	✓	—
FFMXX	—	—	—	—	—	—	—	—	✓	—

1.4 The soffit ventilator provides a means of ventilating the roof void.

1.5 The extruded trims are composed of impact-modified PVC-U and the injection mouldings of PVC-U.

1.6 The fixings for use with various components of the system are listed in Table 3.

Component	Type of fixing
Fascia board	White plastic-headed (12 mm) 40 mm x 3 mm, 50 mm x 3 mm and 65 mm x 3 mm stainless steel annular ring shank nails
Soffit trim	30 mm stainless steel secret-fix cladding pins
Other components	White plastic-headed (7 mm) 25 mm x 2 mm, 30 mm x 2 mm and 40 mm x 2 mm stainless steel annular ring shank nails

(1) Available from the Certificate holder.

2 Manufacture

2.1 The cellular boards comprise a closed-cell cellular PVC-U core beneath an outer weathering, impact-modified PVC-U skin. The boards are manufactured by co-extruding the skin compound onto a foamable core compound, and cooling and forming to section. Cellular PVC-U is formed during the process by the evolution of gas from sodium bicarbonate in the core compound.

2.2 The PVC-U trims are manufactured using conventional extrusion and injection-moulding techniques.

2.3 As part of the assessment and ongoing surveillance of product quality, the BBA has:

- agreed with the Certificate holder the quality control procedures and product testing to be undertaken
- assessed and agreed the quality control operated over batches of incoming materials
- monitored the production process and verified that it is in accordance with the documented process
- evaluated the process for management of nonconformities
- checked that equipment has been properly tested and calibrated
- undertaken to carry out the above measures on a regular basis through a surveillance process, to verify that the specifications and quality control operated by the Certificate holder are being maintained.

2.4 The management system of Freefoam Plastics Limited has been assessed and registered as meeting the requirements of BS EN ISO 9001 : 2015 by SGS [Registration number IE 96/8235 (Cork) and GB 08/75110 (Northampton)].

3 Delivery and site handling

3.1 The boards are delivered in polythene-sleeved packs bearing the product marking and the BBA logo, incorporating the number of this Certificate. Pack quantities vary dependent upon the type of profile.

3.2 Care must be taken when handling PVC-U boards and trims to avoid contact with solvents and materials containing organic components such as coal tar.

3.3 The packs should be unloaded by hand to avoid damage, and stored flat in the polythene sleeves on a clean, level surface in stacks not exceeding one metre in height and restrained from collapse. To avoid damage, it is recommended that additional protection is provided when the planks are stored in the open.

Assessment and Technical Investigations

The following is a summary of the assessment and technical investigations carried out on the Freefoam White PVC-U Roof Trim System.

4 General



4.1 The Freefoam White PVC-U Roof Trim System is suitable for external use to provide a protective and decorative trim at the roofline where timber or other conventional materials would normally be used. The system will provide adequate protection to the interior of the building from the penetration of moisture.

4.2 The system must be fixed only to structurally sound building substrates, at centres not exceeding 600 mm. Rafter feet and gable ladders should be adequately supported to ensure rigidity. Replacement of, rather than fixing over, existing fascia is recommended. Timber roof structures to which the system is fixed must be designed and/or constructed in accordance with the relevant national Building Regulations and BS EN 1995-1-1 : 2004 and its UK national Annex.

4.3 Cellular PVC-UE components have a similar coefficient of thermal expansion to that of conventional solid PVC-U. A 5 mm gap should be provided at the end of each board at the joint trim (ie 10 mm between boards), to allow for movement. Care should be taken not to install the system in extremes of temperature. The recommended temperature for installation is between 5°C and 25°C.

Ventilation



4.4 Ventilation products can contribute towards providing the necessary roof space ventilation. Guidance on the provision of adequate ventilation is given in the national Building Regulations and BS 5250 : 2011, Clause H.

4.5 When providing roof space ventilation, it is essential that the airway must not become blocked by loft insulation. This may be achieved by the use of a suitable BBA-approved insulation retainer producing an air passage with an effective area (geometric free area) at least equal to that of the soffit ventilator used.

4.6 The soffit ventilator trim (without mesh) has a vented area of 25 298 mm² per m run (equivalent to a continuous slot of about 25.3 mm wide at eaves level) and is suitable for the applications given in sections 4.7 to 4.9 .

4.7 For roofs with a pitch of 15° or more, where both the ceiling and insulation are horizontal, soffit ventilation products with a minimum effective area of 10 000 mm² per m run, if used in accordance with section 4.2, can provide adequate ventilation to insulated loft spaces as set out in BS 5250 : 2011, Annex H. To provide adequate cross-ventilation, the soffit ventilation product should run along the eaves of the longest opposite sides of a rectangular roof. The ventilators are suitable for use with traditional (semi-permeable) and high performance (impermeable) sarking felts. Consideration should be given to the use of high-level ventilation openings to increase the ventilation rate for roofs, as recommended in BS 5250 : 2011, Clause H. The use of high-level ventilation openings is strongly recommended in roofs with a pitch greater than 35° or roof spans in excess of 10 m.

4.8 For roofs where the ceiling follows the pitch of the roof, soffit ventilation products with a minimum effective area of 25 000 mm² per m run, if used in conjunction with suitable high-level ventilation, can provide adequately for roof voids as set out in BS 5250 : 2011, Clause H. It is essential that a minimum unrestricted air space of 50 mm is maintained between the underside of the roof deck and the top of the insulation. Consideration should be given to the probability of the sarking felt bowing between rafters and it should be ensured that this does not reduce the gap between felt and insulation to less than 50 mm. Where there is an obstruction to the ventilation (eg rooflights or a change in pitch of roof), adequate ventilation, in accordance with the requirements of BS 5250 : 2011, Clause H, should be provided above and below the obstruction using suitable ventilators. The required ventilation at high level and around obstructions may be achieved by using a suitable BBA-approved ventilator.

4.9 For roofs with a pitch of less than 15°, soffit ventilation products with a minimum effective area of 25 000 mm² per m run, if used in accordance with section 4.2, can provide adequate ventilation to insulated roof voids as set out in BS 5250 : 2011, Clause H. When providing roof space ventilation for flat roofs, it is essential that a minimum unrestricted air space of 50 mm is maintained between the underside of the roof deck and the top of the insulation. Ventilation should be provided along two opposite sides of the deck; where possible, these should be the two longest sides in order to achieve maximum cross-ventilation. The recommendations contained in BS 5250 : 2011,

Clause H, should be followed when planning the provision of ventilation to flat roofs, especially where spans exceed 5 m, or for concrete deck roofs. Where a flat roof has a span greater than 10 m, or is not of a simple rectangular plan, more ventilation will be required, totalling at least 0.6% of the total area of the roof. It should be noted that cold flat roof construction is generally unacceptable in Scotland, and not the preferred option elsewhere in the UK⁽¹⁾.

(1) See BRE Report (BR 262 : 2002) *Thermal insulation: avoiding risks*.

4.10 Where soffit ventilation products are used in lean-to or mono-pitched roofs, high-level ventilation, in accordance with BS 5250 : 2011, Clause H, must be provided.

4.11 Where a pitched roof abuts a wall, additional high-level ventilation must be arranged to provide an open area at least equal to a 5 mm slot running the full length of the abutment.

4.12 Soffit ventilation product sections meet *NHBC* requirements for protection against the ingress of birds, rodents or large insects.

4.13 The dimensions of the slots in soffit ventilation products are such that the risk of blockage is limited. However, blockage by insects and debris will impair their performance as vents and they should be examined occasionally and cleared if necessary.

5 Practicability of installation

The system is designed to be installed by a competent general builder, or a contractor, experienced with this type of system.

6 Strength and stability



6.1 When installed in accordance with this Certificate, the system will withstand, without damage or permanent deflection, the wind loads likely to be encountered in the United Kingdom. In exposed locations, care should be taken to ensure that all profiles are adequately fixed.

6.2 The system has adequate resistance to the hard and soft body impacts likely to occur in practice.

6.3 PVC-U gutters, as specified in BS EN 607 : 2004, may be screw-fixed directly to the Magnum boards. Gutter bracket spacing must not exceed one metre; reduced spacing is recommended in the Scottish Highlands, where snow loading should be considered. Other lightweight gutters may also be screw-fixed to the Magnum board provided that the maximum bracket loading (as covered in BS EN 607 : 2004) is not exceeded. For other boards, all gutters should be fixed through the fascia to rafter ends of other sound timber.

6.4 Magnum boards will support all eaves tiles in common usage in the UK (up to 10 kg load per one metre length of fascia) provided that the boards are installed as per the requirements of this Certificate.

6.5 Apart from the exception detailed in section 6.4, the fascia boards are not loadbearing and must not be used to support fixtures such as roof tiles, gutters, other components of the roof structure or television aerials. Telephone and power cables may be run along the boards but the main brackets for these services should be fixed through the fascia to structurally sound timber.

7 Performance in relation to fire

7.1 When tested in accordance with BS 476-7 : 1997, the cellular boards achieved a Class 1Y surface spread of flame rating, and rigid hollow soffit boards achieved a Class 2Y surface spread of flame rating.

7.2 On exposure to fire, PVC-U tends to char and may fall away. The spread of flame along its surface is limited. It is unlikely that the roof trim system will significantly affect the overall fire performance of any roof in which it is installed.

7.3 Where it is normal practice to carry the eaves box over between dwellings, it is important that the box is fire-stopped at compartment walls.

8 Maintenance



8.1 The system can be cleaned by washing with water and mild detergent. Abrasive or solvent-based cleaners must not be used. For the removal of more resistant stains, the Certificate holder's advice must be sought. If repairs are required, the materials can be cut and drilled using normal woodworking tools.

8.2 As with all PVC products, paint can adversely affect the impact strength of the PVC-U sections, and the application of dark colours could lead to a risk of thermal distortion. Therefore, paint must not be applied.

8.3 The slots of ventilated products should be examined periodically and cleaned if necessary.

9 Durability



9.1 The Freefoam White PVC-U Roof Trim System is as durable as conventional solid PVC-U and profiles will retain adequate impact resistance for a period in excess of 20 years.

9.2 The system will retain its decorative function for its total service life, with only minor changes in surface appearance.

9.3 Where the timber substrate is preservative treated, care must be taken to ensure that sufficient time is allowed for complete fixation of the preservative, to avoid possible corrosion of screws and nails used to fix the components.

10 Reuse and recyclability

The PVC-UE boards and PVC-U trims can be readily recycled.

Installation

11 General

11.1 Installation of the Freefoam White PVC-U Roof Trim System must be carried out in accordance with the Certificate holder's instructions and the requirements of this Certificate (see Figures 3 and 4).

Figure 3 Typical fascia and soffit installation details

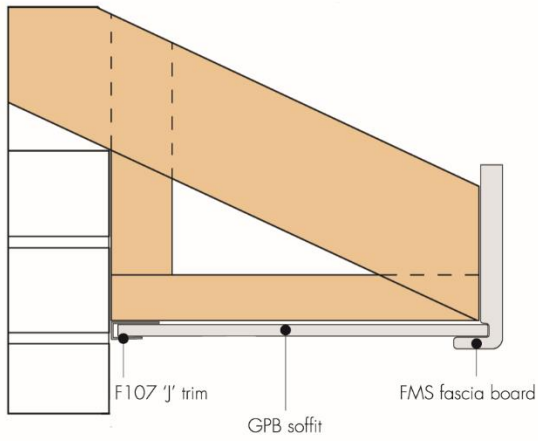

Magnum fascia without backing board

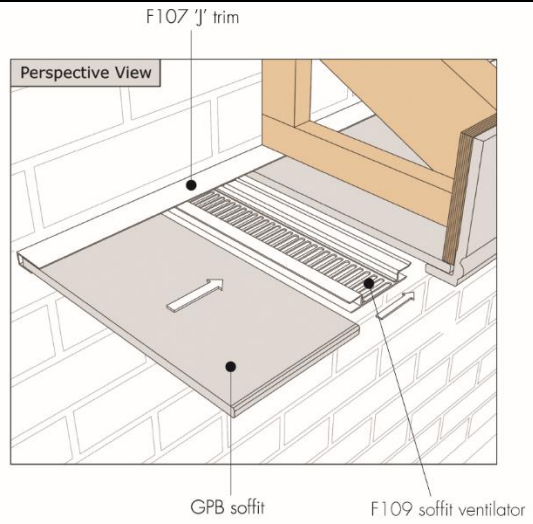

vented soffit joiner detail — perpendicular

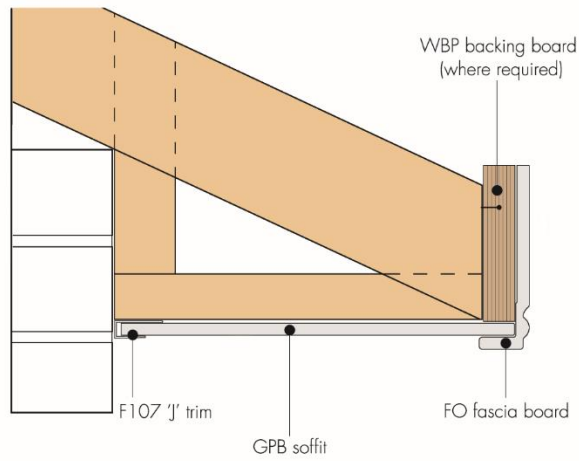

fascia with backing board

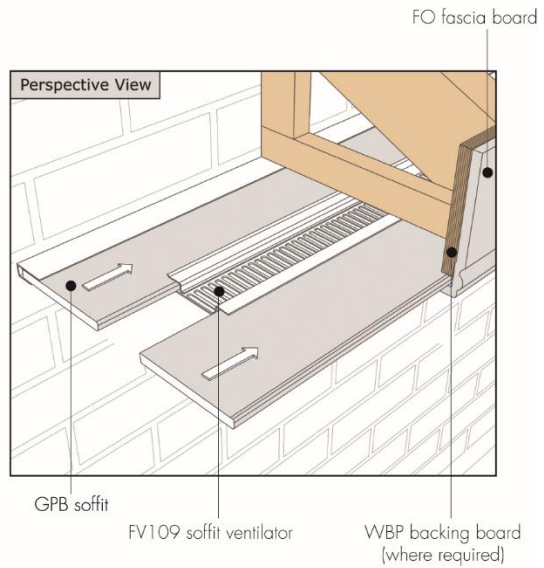

vented soffit detail — parallel

Figure 4 Typical soffit box detail

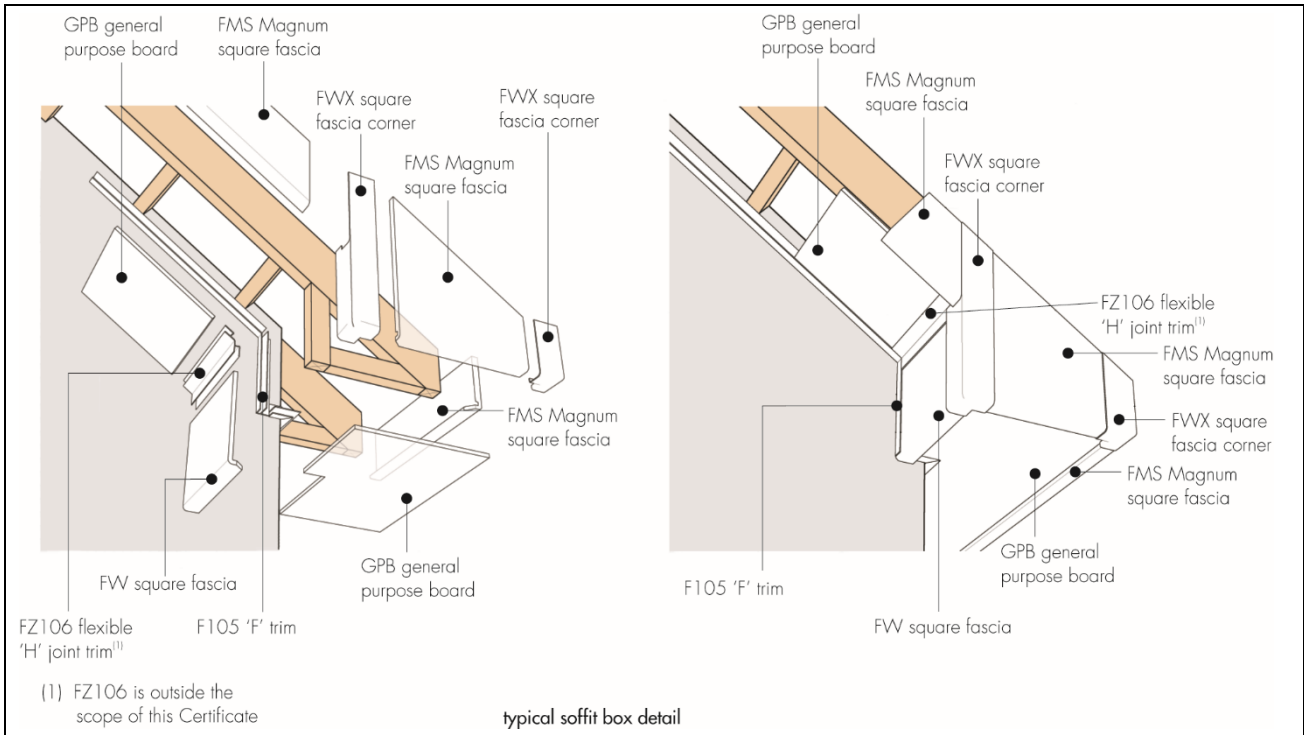

11.2 Fascia, soffit and barge boards should be fixed to structurally sound timber at centres not exceeding 600 mm, using the nails and pins specified by the Certificate holder. Rotten timber must be replaced by new, treated timber.

11.3 Magnum fascia boards may be used directly to support PVC-U and other lightweight gutters (see section 6.3). Other components of the system are not loadbearing (see section 6.5).

11.4 Magnum boards may be used to support eaves tiles (see section 6.4). In certain geographical/topographical locations, the eaves tiles will need to be restrained in order to resist wind uplift. Guidance on this fixing should be sought from the Certificate holder of the eaves tiles.

11.5 Sarking felt should be checked to ensure that it is in good condition and that it extends onto the verge rafter and over a felt support into the gutter at the eaves. Damaged or worn felt should be replaced or, if occurring at the eaves, made watertight using an eaves protector.

11.6 Soffit ventilation products should be selected and installed so that the roof ventilation conforms to the relevant Building Regulations.

11.7 Normal precautions should be taken when working at roof level. The use of protective goggles when cutting and nailing is recommended.

11.8 The components of the system are easy to work using normal woodworking tools for cutting, drilling and shaping. Handsaws should have a fine-toothed blade. Hand-held and bench-mounted power tools with a carbide-tipped blade should be run at speeds similar to, or higher than, those normally used for timber.

11.9 When using power tools to cut or shape the product, it is advisable to use a coarse particle dust mask and eye protection.

11.10 No special training is required to install the roof trim system correctly, provided the Certificate holder's instructions and the procedures outlined in section 11 of this Certificate are followed.

12 Procedure

12.1 Selected boards and accessories are assembled and cut to size.

12.2 Rafter feet are cut to a line.

12.3 Noggings, soffit bearers, battens, eaves fillets, brackets and other additional timber supports are fixed to a sound substrate.

12.4 Protective films should be removed just prior to fixing, ie peeled off as nailing progresses along the board.

12.5 The summary for the installation details of fascia, soffit and barge boards (see sections 12.6 to 12.17) should be read with reference to the appropriate diagrams in Figures 3 and 4.

Fascia boards

12.6 Fascia boards are fixed to rafter feet at centres not exceeding 600 mm, using two specified ring-shanked nails. Magnum boards may be fixed directly to rafter feet using 65 mm long nails. For other boards, however, it is normal practice to fix⁽¹⁾ to the rafter feet through a 25 mm thick, marine plywood backing board or equivalent, which has been previously fixed to the rafter timbers.

(1) Using nails at least 40 mm long.

12.7 Butt joints between fascia boards should be made at the rafter with a 10 mm wide expansion gap between, and with both boards fixed to the rafter foot. A joiner trim is fixed to one board only with a specified 25 or 30 mm long nail or a suitable low-modulus silicone sealant.

12.8 At corners, both boards are fixed to sound timber, allowing a 5 mm expansion gap at the end of each board. A corner trim is fixed to the end of one board as described in section 12.7.

12.9 Internal corner joints are covered by internal corner trims. These are fixed to the end of one board with a low-modulus neutral-cure silicone as described for the adhesive external corner joint in section 12.8.

12.10 For the Magnum boards, gutter brackets may be fixed directly into the board using, for each bracket, at least two 25 mm long by 4.8 mm diameter parallel thread form screws recommended by the Certificate holder, ensuring that the screws penetrate the rear face of the board and that the bracket spacing does not exceed 1 metre. For the 9 mm board, gutter brackets are screwed through the fascia board into the timber support.

Soffit boards

12.11 Soffits are made from cellular soffit boards or rigid hollow soffits. The latter may be used lengthways or in short lengths at right angles to the wall. To give a tongue-and-groove effect, the indented face should be exposed.

12.12 The soffit should fit into or onto the fascia and into a trim or onto a nogging on the wall.

12.13 The boards are fixed to rafter feet, soffit bearers or other timber support at centres not exceeded 600 mm along their length or 150 mm across their width, using the specified 30 mm nails.

12.14 Where required, soffit boards may be joined along their length or width using a joint trim.

12.15 To comply with the national Building Regulations, a ventilator trim is incorporated into the soffit, as necessary.

Barge boards

12.16 Barge boards are installed by fixing fascia boards to a gable ladder, rafter face or noggings, using the procedures given for fascia boards in section 12.6.

12.17 Barge boards meeting at a ridge should be mitred to the appropriate angle.

12.18 Box ends are constructed from fascia board and trims to suit the roof pitch and overhang requirement. Any timber framework required for the construction of the box end must be preservative treated.

13 Tests

13.1 Results of tests conducted on the Freefoam White PVC-U Roof Trim System were assessed to determine:

- weight per linear metre
- density
- ash content
- impact strength
- dimensional stability
- resistance to impact after UV ageing
- resistance to impact at low temperature
- accelerated weathering
- natural weathering
- nail pull-through
- water absorption
- heat reversion
- resistance to acetone
- Vicat softening temperature
- flexural strength and modulus of elasticity
- resistance to heat ageing
- resistance to tile and gutter loading.

13.2 An assessment was made of existing test data relating to:

- surface spread of flame
- colour stability.

14 Investigations

14.1 After establishing the nail pull-through values, calculations were undertaken to establish the resistance of the product to wind suction.

14.2 The dimensions of the cellular boards and trims were checked.

14.3 An assessment was made of the acceptability of the soffit ventilator to satisfy ventilation requirements.

14.5 The manufacturing process, including the methods adopted for quality control, were examined and details were obtained of the quality and composition of the materials used.

14.6 The practicability of installation was assessed.

Bibliography

BS 476-7 : 1997 *Fire tests on building materials and structures — Method of test to determine the classification of the surface spread of flame of products*

BS 5250 : 2011 *Code of practice for control of condensation in buildings*

BS EN 607 : 2004 *Eaves gutters and fittings made of PVC-U — Definitions, requirements and testing*

BS EN 1995-1-1 : 2004 *Eurocode 5 : Design of timber structures — General — Common rules and rules for buildings*

BS EN 12200-1 : 2016 *Plastics rainwater piping systems for above ground external use unplasticized poly (vinyl chloride) (PVC-U) — Specifications for pipes, fittings and the system*

BS EN ISO 9001 : 2015 *Quality management systems — Requirements*

BRE Report 262 : *Thermal insulation : avoiding risks*

15 Conditions

15.1 This Certificate:

- relates only to the product/system that is named and described on the front page
- is issued only to the company, firm, organisation or person named on the front page – no other company, firm, organisation or person may hold claim that this Certificate has been issued to them
- is valid only within the UK
- has to be read, considered and used as a whole document – it may be misleading and will be incomplete to be selective
- is copyright of the BBA
- is subject to English Law.

15.2 Publications, documents, specifications, legislation, regulations, standards and the like referenced in this Certificate are those that were current and/or deemed relevant by the BBA at the date of issue or reissue of this Certificate.

15.3 This Certificate will remain valid for an unlimited period provided that the product/system and its manufacture and/or fabrication, including all related and relevant parts and processes thereof:

- are maintained at or above the levels which have been assessed and found to be satisfactory by the BBA
- continue to be checked as and when deemed appropriate by the BBA under arrangements that it will determine
- are reviewed by the BBA as and when it considers appropriate.

15.4 The BBA has used due skill, care and diligence in preparing this Certificate, but no warranty is provided.

15.5 In issuing this Certificate the BBA is not responsible and is excluded from any liability to any company, firm, organisation or person, for any matters arising directly or indirectly from:

- the presence or absence of any patent, intellectual property or similar rights subsisting in the product/system or any other product/system
- the right of the Certificate holder to manufacture, supply, install, maintain or market the product/system
- actual installations of the product/system, including their nature, design, methods, performance, workmanship and maintenance
- any works and constructions in which the product/system is installed, including their nature, design, methods, performance, workmanship and maintenance
- any loss or damage, including personal injury, howsoever caused by the product/system, including its manufacture, supply, installation, use, maintenance and removal
- any claims by the Certificate holder relating to CE marking.

15.6 Any information relating to the manufacture, supply, installation, use, maintenance and removal of this product/system which is contained or referred to in this Certificate is the minimum required to be met when the product/system is manufactured, supplied, installed, used, maintained and removed. It does not purport in any way to restate the requirements of the Health and Safety at Work etc. Act 1974, or of any other statutory, common law or other duty which may exist at the date of issue or reissue of this Certificate; nor is conformity with such information to be taken as satisfying the requirements of the 1974 Act or of any statutory, common law or other duty of care.