

Hambleside Danelaw Ltd

Long March
Daventry

Northamptonshire NN11 4NR

Tel: 01327 701900 Fax: 01327 701909

e-mail: sales@hambleside-danelaw.co.uk

website: www.hambleside-danelaw.co.uk



Agrément Certificate
87/1915
Product Sheet 3

HAMBLESIDE DANELAW GRP FLASHINGS

HAMBLESIDE DANELAW GRP BONDING GUTTERS

This Agrément Certificate Product Sheet⁽¹⁾ relates to Hambleside Danelaw GRP Bonding Gutters, for use in slated or tiled roofs constructed in accordance with the relevant requirements of BS 5534 : 2014. The bonding gutters provide a weatherproof jointing method at the junction of different slate and/or tiled roof coverings in the same plane.

(1) Hereinafter referred to as 'Certificate'.

CERTIFICATION INCLUDES:

- factors relating to compliance with Building Regulations where applicable
- factors relating to additional non-regulatory information where applicable
- independently verified technical specification
- assessment criteria and technical investigations
- design considerations
- installation guidance
- regular surveillance of production
- formal three-yearly review.

KEY FACTORS ASSESSED

Weathertightness — as part of a complete roof, the products will resist the passage of moisture into the interior of the building (see section 6).

Properties in relation to fire — tests indicate that the products, when used as part of a complete roof, will be unrestricted under the Building Regulations (see section 7).

Strength — the products have adequate strength to resist the normal loads and impacts associated with the installation of the roof (see section 8).

Durability — under normal service conditions, the products will have a service life of at least 20 years (see section 10).



The BBA has awarded this Certificate to the company named above for the products described herein. These products have been assessed by the BBA as being fit for their intended use provided they are installed, used and maintained as set out in this Certificate.

On behalf of the British Board of Agrément

A handwritten signature in black ink, appearing to read 'John Albon'.

John Albon — Head of Approvals
Construction Products

A handwritten signature in black ink, appearing to read 'Claire Curtis-Thomas'.

Claire Curtis-Thomas
Chief Executive

Date of Second issue: 23 July 2015

Originally certificated on 20 September 1987

The BBA is a UKAS accredited certification body — Number 113. The schedule of the current scope of accreditation for product certification is available in pdf format via the UKAS link on the BBA website at www.bbacerts.co.uk

Readers are advised to check the validity and latest issue number of this Agrément Certificate by either referring to the BBA website or contacting the BBA direct.

British Board of Agrément
Bucknalls Lane
Watford
Herts WD25 9BA

©2015

tel: 01923 665300
fax: 01923 665301
clientservices@bba.star.co.uk
www.bbacerts.co.uk

Regulations

In the opinion of the BBA, Hambleside Danelaw GRP Bonding Gutters, if installed, used and maintained in accordance with this Certificate, can satisfy or contribute to satisfying the relevant requirements of the following Building Regulations (the presence of a UK map indicates that the subject is related to the Building Regulations in the region or regions of the UK depicted):



The Building Regulations 2010 (England and Wales) (as amended)

Requirement: B4(2)	External fire spread
Comment:	Data to BS 476-3 : 1958 indicate that the products, when used as part of a complete roof, will not affect the fire rating of the roof construction. See section 7 of this Certificate.
Requirement: C2(b)	Resistance to moisture
Comment:	The products will contribute to a roof meeting this Requirement. See section 6 of this Certificate.
Regulation: 7	Materials and workmanship
Comment:	The products are acceptable. See section 10 and the <i>Installation</i> part of this Certificate.



The Building (Scotland) Regulations 2004 (as amended)

Regulation: 8(1)(2)	Durability, workmanship and fitness of materials
Comment:	The use of the products satisfies the requirements of this Regulation. See sections 9 and 10 and the <i>Installation</i> part of this Certificate.
Regulation: 9	Building standards applicable to construction
Standard: 2.8	Spread from neighbouring buildings
Comment:	Data to BS 476-3 : 1958 indicate that the products can be regarded as having a low vulnerability with reference to clause 2.8.1 ⁽¹⁾⁽²⁾ , and will not affect the fire rating of the roof construction. See section 7 of this Certificate.
Standard: 3.10	Precipitation
Comment:	The products will contribute to a roof satisfying clauses 3.10.1 ⁽¹⁾⁽²⁾ and 3.10.8 ⁽¹⁾⁽²⁾ of this Standard. See section 6 of this Certificate.
Standard: 7.1(a)	Statement of sustainability
Comment:	The products can contribute to meeting the relevant requirements of Regulation 9, Standards 1 to 6 and therefore will contribute to a construction meeting a bronze level of sustainability as defined in this Standard.
Regulation: 12	Building standards applicable to conversions
Comment:	Comments made in relation to the products under Regulation 9, Standards 1 to 6 also apply to this Regulation, with reference to clause 0.12.1 ⁽¹⁾⁽²⁾ and Schedule 6 ⁽¹⁾⁽²⁾ . (1) Technical Handbook (Domestic). (2) Technical Handbook (Non-Domestic).



The Building Regulations (Northern Ireland) 2012 (as amended)

Regulation: 23(a)(i)(iii)(b)(i)	Fitness of materials and workmanship
Comment:	The products are acceptable. See section 10 and the <i>Installation</i> part of this Certificate.
Regulation: 28(b)	Resistance to moisture and weather
Comment:	The products will contribute to a roof satisfying this Regulation. See section 6 of this Certificate.
Regulation: 36(b)	External fire spread
Comment:	Data to BS 476-3 : 1958 indicate that the products, when used as part of a complete roof construction, will not affect the fire rating of the roof construction. See section 7 of this Certificate.

Construction (Design and Management) Regulations 2015

Construction (Design and Management) Regulations (Northern Ireland) 2007

Information in this Certificate may assist the client, Principal Designer/CDM co-ordinator, designer and contractors to address their obligations under these Regulations.

See sections: 1 *Description* (1.3) and 3 *Delivery and site handling* (3.1) of this Certificate.

Additional Information

NHBC Standards 2014

NHBC accepts the use of Hambleside Danelaw GRP Bonding Gutters for slated and tiled roofs, provided they are installed, used and maintained in accordance with this Certificate, in relation to *NHBC Standards, Part 7 Roofs, Chapter 7.2 Pitched roofs*.

Technical Specification

1 Description

1.1 The Hambleside Danelaw GRP Bonding Gutters are manufactured from glassfibre-reinforced polyester (GRP) laminates to the profiles illustrated in Figures 1 and 2.

Figure 1 Bonding Gutter

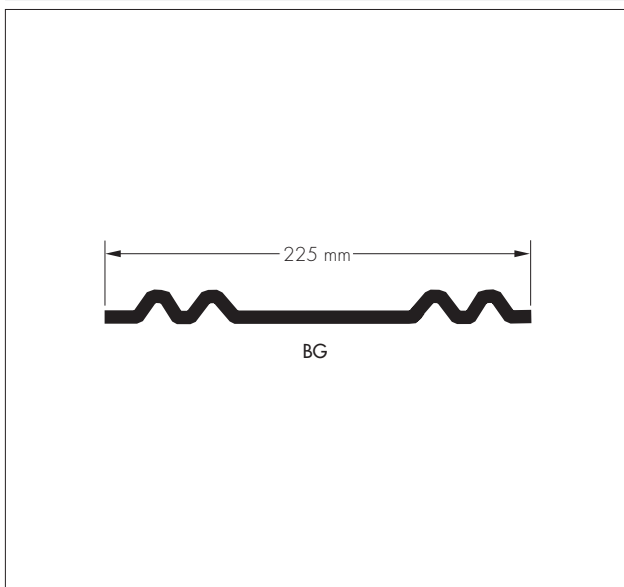
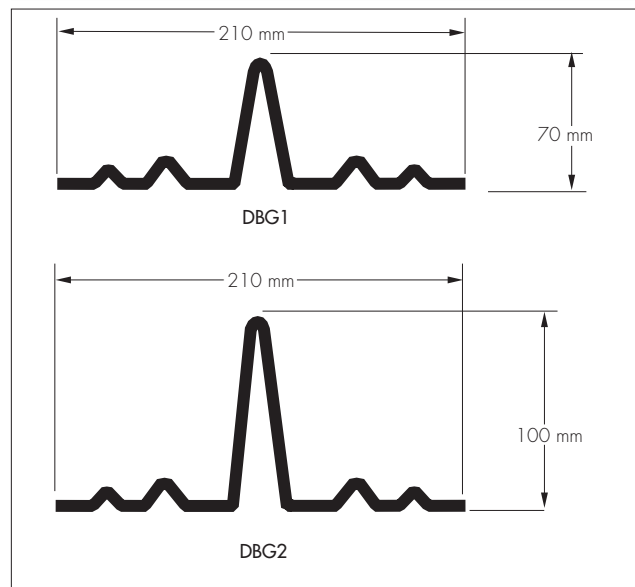

Figure 2 Dry Fix Bonding Gutter



1.2 The codes of the products are:

- BG – Bonding Gutter
- DBG1 and DBG2 – Dry Fix Bonding Gutters.

1.3 Product BG has a mortar bonding strip along the centre line of the upper surface.

1.4 DBG1 incorporates a central upstand of 70 mm to suit slates and flat interlocking and plain tiles. DBG2 has a central upstand of 100 mm to suit profiled tiles (one or both sides) and typical Scottish practice, where tiling battens may occur on one side only.

1.5 The products are supplied in 3 m lengths and in widths of:

BG	225 mm
DBG1 and DBG2	210 mm.

1.6 The gutters are finished in Standard Grey and have a laminated film on the upper surface, giving a gloss finish which improves the weather resistance of the GRP.

2 Manufacture

2.1 The products are manufactured in a continuous process. Glassfibre mats are impregnated with resin and laminated with a polyester carrier film and a weather protection film to the required profile.

2.2 As part of the assessment and ongoing surveillance of product quality, the BBA has:

- agreed with the manufacturer the quality control procedures and product testing to be undertaken
- assessed and agreed the quality control operated over batches of incoming materials
- monitored the production process and verified that it is in accordance with the documented process
- evaluated the process for management of nonconformities
- checked that equipment has been properly tested and calibrated
- undertaken to carry out the above measures on a regular basis through a surveillance process, to verify that the specifications and quality control operated by the manufacturer are being maintained.

2.3 The management system of Hambleside Danelaw Ltd has been assessed and registered as meeting the requirements of BS EN ISO 9001 : 2008 by BSI (Certificate FM 23063).

3 Delivery and site handling

3.1 The products are delivered to site in packs of 10 units, each unit marked with size, the application and the BBA logo including the number of this Certificate.

3.2 The packs must be stored flat or on end, on a smooth, clean, dry surface, under cover and protected from sunlight.

Assessment and Technical Investigations

The following is a summary of the assessment and technical investigations carried out on Hambleside Danelaw GRP Bonding Gutters.

Design Considerations

4 Use

Hambleside Danelaw GRP Bonding Gutters are satisfactory for use in tiled or slated pitched roofs constructed in accordance with the relevant clauses of BS 5534 : 2014, to provide a weatherproof junction where there are changes in direction or material in a roof structure.

5 Practicability of installation

Installation is designed to be carried out readily by slaters/tilers experienced with this type or product.

6 Weathertightness



Results of tests indicate that the products will adequately resist the passage of moisture to the interior of a building and so meet the requirements of the national Building Regulations.

7 Properties in relation to fire



When tested in accordance with BS 467-3 : 1958, samples of GRP representative of that used in the manufacture of the products achieved an EXT.S.AB rating.

8 Strength

The products will resist the normal loads and impacts associated with installation and use.

9 Maintenance



Minimal maintenance is necessary and the smooth finish will inhibit the build up of foreign matter.

10 Durability



Available test data and knowledge of the material indicate that the products will have an expected life of at least 20 years.

Installation

11 General

Installation of Hambleside Danelaw GRP Bonding Gutters must be in accordance with the Certificate holder's instructions, the product label and the relevant recommendations of BS 5534 : 2014 and BS 8000-6 : 2013.

12 Procedure

12.1 The underlay and battens over the joint area of the party wall should be made good. Battens may cross over the party wall without trimming.

12.2 The adjoining roof must be prepared by marking and cutting the tiles or slates to a straight line, midway over the party wall, and renewing or replacing any defective or decayed underlay, battens and nails back to the nearest appropriate rafter.

12.3 The bonding gutter is positioned and nailed to the battens (or sarking boards in Scottish practice) through the outer flanges only and at 500 mm centres maximum, using nails of a quality acceptable in good roofing practice.

12.4 Consecutive lengths of the bonding gutter are laid, allowing a 150 mm overlap when measured vertically at the joints and extending over the fascia board into the gutter.

12.5 With the BG bonding gutter, the tiles or slates are fixed with a butt joint over the centre of the bonding gutter and bedded onto mortar or mastic laid on the mortar bonding strip. The water channels must be left free from mortar or mastic (see Figure 3).

Figure 3 Typical installation using the BG Gutter

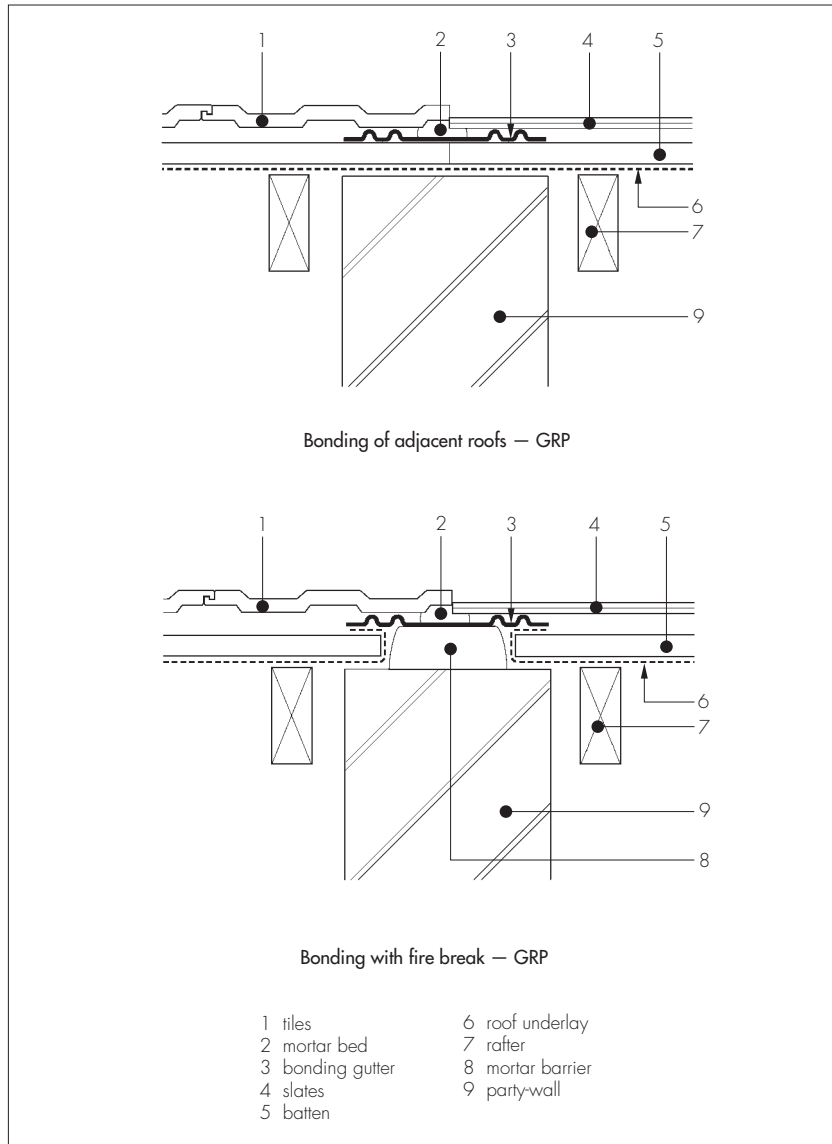

12.6 With the DBG1 and DBG2 bonding gutters, the sides of the central upstand should be pinched together when nailing, and the slates or tiles should be laid close to or touching the central upstand on both sides (see Figure 4). Care should be taken to:

- avoid any pressure or distortion
- maintain the straight line appearance of the profile
- avoid nailing into or between the water channels.

Figure 4 Typical installation using the DBG1 and DBG2 Gutter

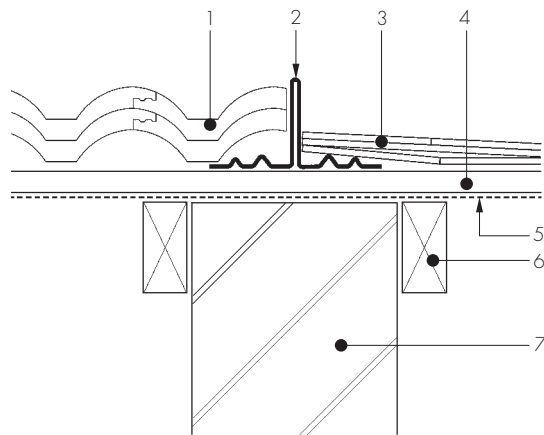

Bonding of adjacent roofs — Dry Fix

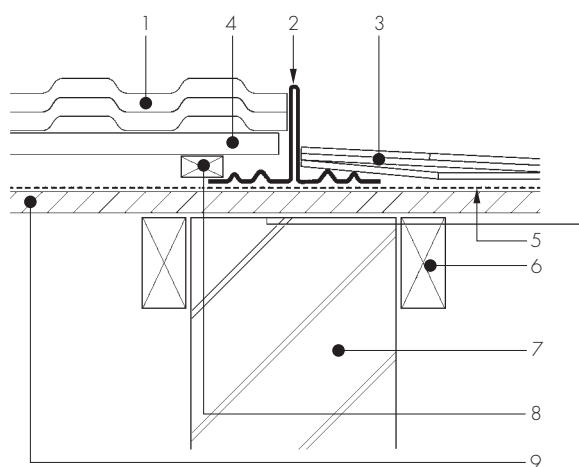

Typical Scottish installation

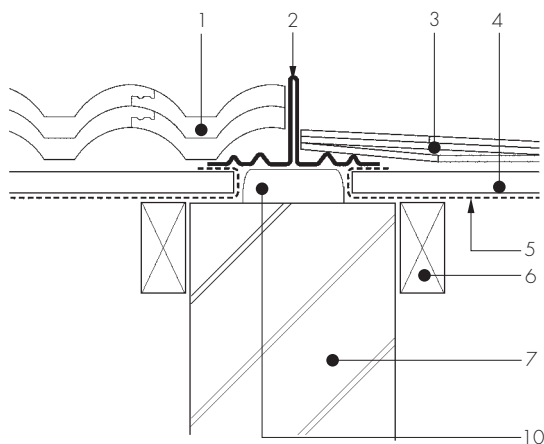

Bonding with fire break — Dry Fix

- | | |
|------------------|-------------------|
| 1 tiles | 6 rafter |
| 2 bonding gutter | 7 party wall |
| 3 slates | 8 counter batten |
| 4 batten | 9 sarking board |
| 5 roof underlay | 10 mortar barrier |

13 Tests

Tests were conducted and the results assessed to determine:

- density
- glass/resin ratio
- hardness
- cross-breaking strength
- impact resistance
- effect of elevated temperatures
- effect of water soak.

14 Investigations

14.1 An assessment was made of the results of a fire test in accordance with BS 476-3 : 1958 carried out by an independent test authority.

14.2 A survey of users was carried out to assess performance in use.

14.3 The manufacturing process was evaluated, including the methods adopted for quality control, and details were obtained of the quality and composition of the materials used.

Bibliography

BS 476-3 : 1958 *Fire tests on building materials and structures — Classification and method of test for external fire exposure to roofs*

BS 5534 : 2014 *Slating and tiling for pitched roofs and vertical cladding — Code of practice*

BS 8000-6 : 2013 *Workmanship on building sites — Code of practice for slating and tiling of roofs and walls*

BS 8747 : 2007 *Reinforced bitumen membranes (RBMs) for roofing — Guide to selection and specification*

BS EN ISO 9001 : 2008 *Quality management systems — Requirements*

15 Conditions

15.1 This Certificate:

- relates only to the product/system that is named and described on the front page
- is issued only to the company, firm, organisation or person named on the front page — no other company, firm, organisation or person may hold or claim that this Certificate has been issued to them
- is valid only within the UK
- has to be read, considered and used as a whole document — it may be misleading and will be incomplete to be selective
- is copyright of the BBA
- is subject to English Law.

15.2 Publications, documents, specifications, legislation, regulations, standards and the like referenced in this Certificate are those that were current and/or deemed relevant by the BBA at the date of issue or reissue of this Certificate.

15.3 This Certificate will remain valid for an unlimited period provided that the product/system and its manufacture and/or fabrication, including all related and relevant parts and processes thereof:

- are maintained at or above the levels which have been assessed and found to be satisfactory by the BBA
- continue to be checked as and when deemed appropriate by the BBA under arrangements that it will determine
- are reviewed by the BBA as and when it considers appropriate.

15.4 The BBA has used due skill, care and diligence in preparing this Certificate, but no warranty is provided.

15.5 In issuing this Certificate, the BBA is not responsible and is excluded from any liability to any company, firm, organisation or person, for any matters arising directly or indirectly from:

- the presence or absence of any patent, intellectual property or similar rights subsisting in the product/system or any other product/system
- the right of the Certificate holder to manufacture, supply, install, maintain or market the product/system
- actual installations of the product/system, including their nature, design, methods, performance, workmanship and maintenance
- any works and constructions in which the product/system is installed, including their nature, design, methods, performance, workmanship and maintenance
- any loss or damage, including personal injury, howsoever caused by the product/system, including its manufacture, supply, installation, use, maintenance and removal
- any claims by the manufacturer relating to CE marking.

15.6 Any information relating to the manufacture, supply, installation, use, maintenance and removal of this product/system which is contained or referred to in this Certificate is the minimum required to be met when the product/system is manufactured, supplied, installed, used, maintained and removed. It does not purport in any way to restate the requirements of the Health and Safety at Work etc. Act 1974, or of any other statutory, common law or other duty which may exist at the date of issue or reissue of this Certificate; nor is conformity with such information to be taken as satisfying the requirements of the 1974 Act or of any statutory, common law or other duty of care.