

**Tile Ventilator Range - Plain Tile**

CODE **GTV-PT**

**Description**

The Manthorpe in-line plain tile ventilator is designed to provide a quick and simple solution to the problems of roofspace ventilation and mechanical extraction / soil stack termination through a plain tiled roof. The vent is quick and easy to install, taking the place of a 3 plain tiles with no need to cut the battens. The in-line profile helps to maintain an unbroken appearance to the roofline whether used at high or low level.

The tortured path through the internal weathering geometry is designed to maintain a constant airflow gap of 7,000 mm<sup>2</sup> whilst channelling any water ingress out of the vent and on to the roof covering below, with the 4mm louvred grill and placed to prevent the entry of debris and large nesting insects.

Available in a range of four colours to suit most styles of concrete and traditional clay plain tiles from all major UK and Irish tile manufacturers.

For use with mechanical extraction or soil stack / vent pipe termination; the GTV-AD Flexi Pipe Adaptor and GRPA Flexible Pipe range should be used. For detailed fitting instructions see MBP-0968, and for mechanical extraction fitting details see MBP-8292.

<b>Weight</b>	0.78kg
<b>Box Qty</b>	6 (5.25kg per box)
<b>Materials - Top Base</b>	PVC Polypropylene
<b>Colours</b>	Terracotta, Grey, Brown & Antique Red
<b>Manufacturing</b>	Injection Moulded
<b>Free Airflow</b>	7,000 mm <sup>2</sup> per unit

**Features**

- In-line and discreet low profile design.
- 4mm louvred flyscreen grill.
- No batten cutting required.
- Range of colours available.
- Suitable for concrete and traditional clay tiles.
- Profiles suit all top tile manufacturers.
- Fully independently wind tunnel tested.
- Base outlet feeds directly into roof space.
- Adaptor available for mechanical extraction.
- Suitable for use down to a 35° roof pitch.

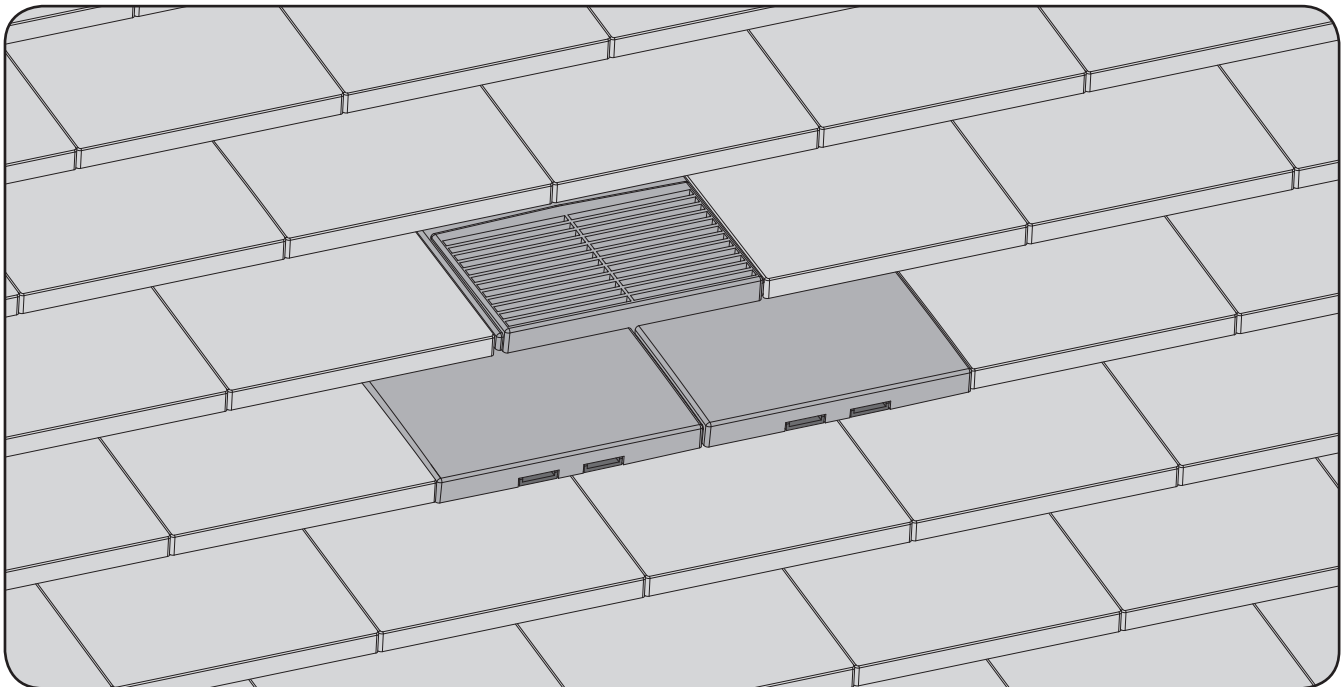

MANTHORPE BUILDING PRODUCTS LTD  
 MANTHORPE HOUSE  
 BRITAIN DRIVE  
 CODNOR GATE BUSINESS PARK  
 RIPLEY  
 DERBYSHIRE DE5 3ND

TEL: 01773 303 000  
 FAX: 01773 303 300  
 EMAIL:  
 customercare@manthorpebp.co.uk  
 WEB  
 www.manthorpebp.co.uk

DRN B.H. Date 20.06.19

The company maintains a policy of continuous development of its product range and reserves the right to amend the specification without notice.

DRG No

**MBP 8307**

Issue

**B**  
1 of 2

**Tile Ventilator Range - Plain Tile**

CODE **GTV-PT**

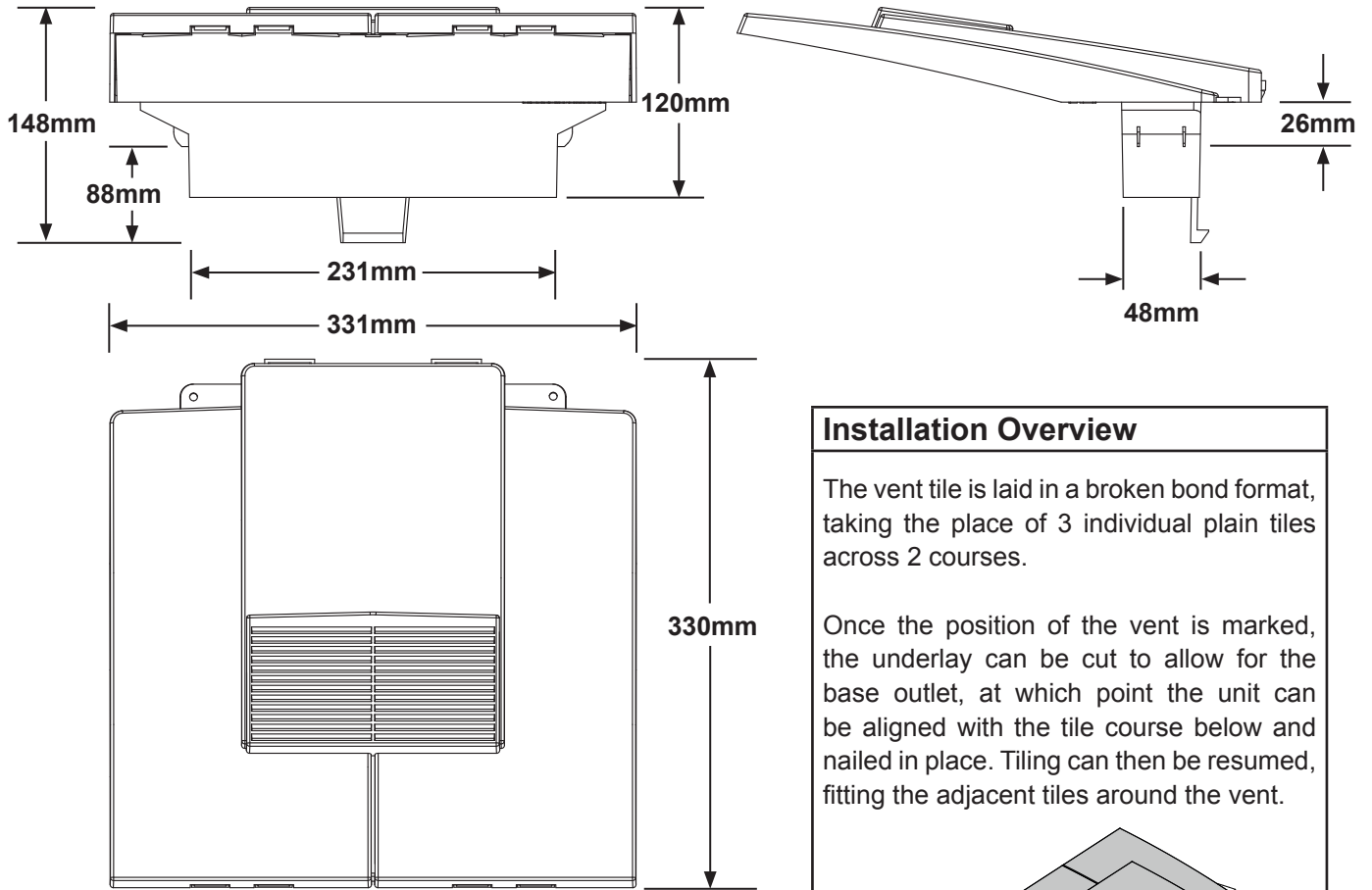

**Installation Overview**

The vent tile is laid in a broken bond format, taking the place of 3 individual plain tiles across 2 courses.

Once the position of the vent is marked, the underlay can be cut to allow for the base outlet, at which point the unit can be aligned with the tile course below and nailed in place. Tiling can then be resumed, fitting the adjacent tiles around the vent.

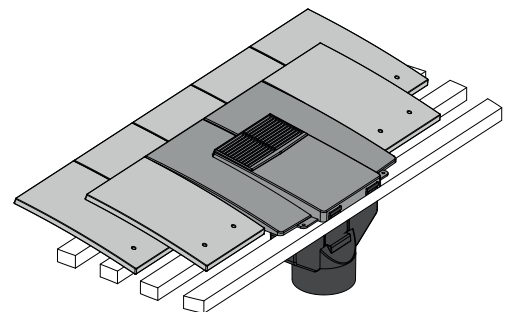

The vent outlet is designed to penetrate through the roofing underlay between the tile courses, meaning there is no need to cut or trim the battens, even when laid at the lowest batten gauge of 88mm (when using 38mm roofing battens).

**NOTE:** When using the vent for mechanical extraction, the pipe adaptor is fitted from inside the roof space.

Required Ventilation	Vent Spacing
5,000 mm <sup>2</sup> /m	Install at 1.4m centres
10,000 mm <sup>2</sup> /m	Install at 0.7m centres
25,000 mm <sup>2</sup> /m	Install at 0.28m centres

**References**

- BSI: BS 5250:2002 Control of Condensation in Building
- BSI: BS 5534:2003 Code of Practice for Slate and Tiling
- BSI: BS 490:2004 Concrete tiles and fittings for roof covering
- BRE: prEN 15601
- Building Regulations 2010
- NHBC: Good Craftsmanship Guides

MANTHORPE BUILDING PRODUCTS LTD  
 MANTHORPE HOUSE  
 BRITAIN DRIVE  
 CODNOR GATE BUSINESS PARK  
 RIPLEY  
 DERBYSHIRE DE5 3ND

TEL: 01773 303 000  
 FAX: 01773 303 300  
 EMAIL: customercare@manthorpebp.co.uk  
 WEB: www.manthorpebp.co.uk

DRN B.H. Date 20.06.13  
 The company maintains a policy of continuous development of its product range and reserves the right to amend the specification without notice.

DRG No  
**MBP 8307**

Issue  
**B**  
 2 of 2