

Tile Ventilator Range - Castellated Tile

CODE **GTV-CS**

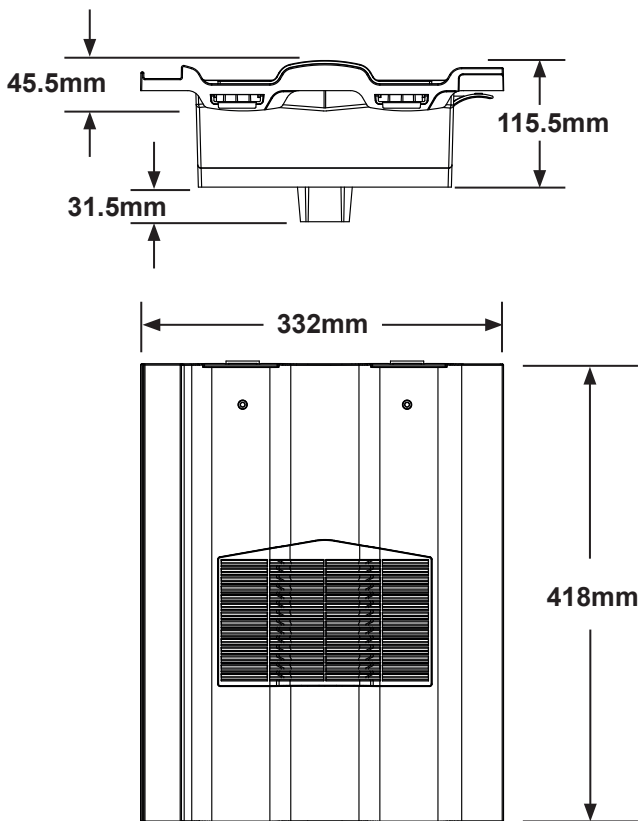

Description

The Manthorpe Castellated in-line tile ventilator is designed to provide a quick and simple solution to the problems of roofspace ventilation and mechanical extraction / soil stack termination through a square topped profile tiled roof.

The profile vent is designed to replace a single tile and maintain an unbroken appearance to the roofline whether used at high or low level.

The tortured path through the 4mm louvred grill and internal weathering geometry is designed to maintain a 10k mm² of airflow whilst channelling any water ingress out of the vent and on to the roof covering.

Weight	1.06kg
Box Qty	4 (4.5kg per box)
Materials - Top Base	PVC Polypropylene
Colours	Terracotta, Grey, Brown & Antique Red
Manufacturing	Injection Moulded
Free Airflow	10K mm ² per unit

Features

- In-line and discreet low profile design.
- 4mm louvred flyscreen grill.
- Integral sidelock clip to ensure secure fit.
- Range of profiles and colours available.
- Profiles suit all top tile manufacturers.
- Fully independently wind tunnel tested.
- Base outlet feeds directly into roof space.
- Adaptor available for mechanical extraction.
- Suitable for use down to a 20° roof pitch.

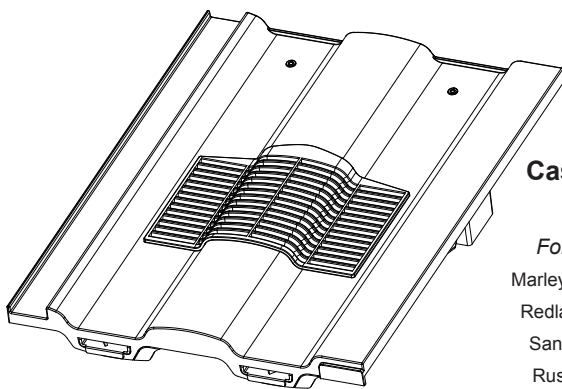

Castellated Tile

For use with:
Marley Ludlow Major
Redland Renown*
Sandtoft Lindum
Russell Cheviot
Lagan Square Top

* Profile requires vent modification.

References

BSI: BS 5250:2002 Control of Condensation in Building
BSI: BS 5534:2003 Code of Practice for Slate and Tiling
BSI: BS 490:2004 Concrete tiles and fittings for roof covering
BRE: prEN 15601
Building Regulations 2010
NHBC: Good Craftmanship Guides

MANTHORPE BUILDING PRODUCTS LTD
MANTHORPE HOUSE
BRITAIN DRIVE
CODNOR GATE BUSINESS PARK
RIPLEY
DERBYSHIRE DE5 3ND

TEL: 01773 303 000
FAX: 01773 303 300
EMAIL:
customer@manthorpebp.co.uk
WEB
www.manthorpebp.co.uk

DRN B.H. Date 19.06.19

The company maintains a policy of continuous development of its product range and reserves the right to amend the specification without notice.

DRG No

MBP 8296

Issue

B