

**Tile Ventilator Range - Double Pantile**

CODE **GTV-DP**

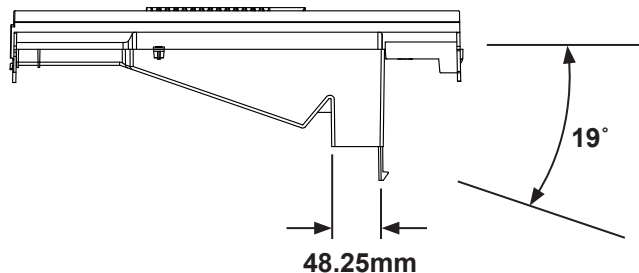
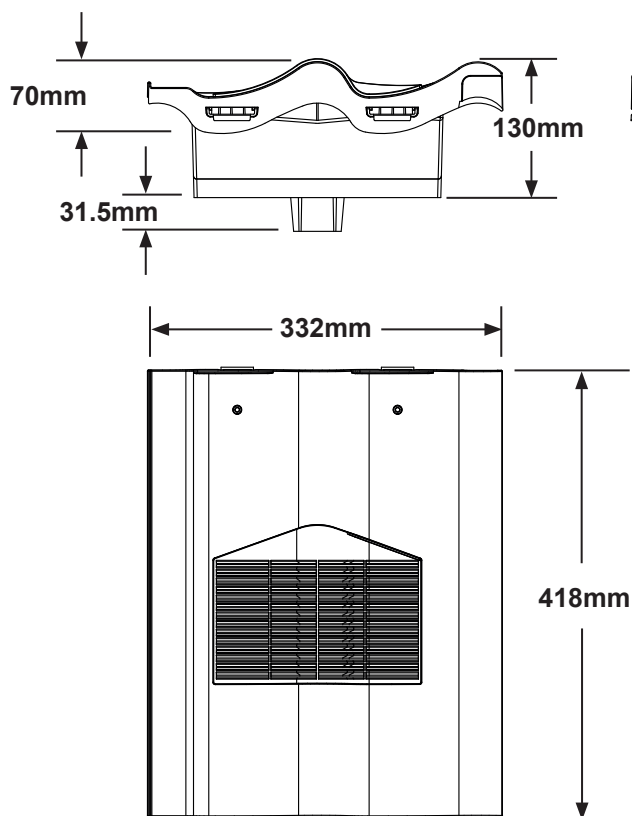

**Description**

The Manthorpe Double Pantile in-line tile ventilator is designed to provide a quick and simple solution to the problems of roofspace ventilation and mechanical extraction / soil stack termination through a Double Pantile tiled roof.

The profile vent is designed to replace a single tile and maintain an unbroken appearance to the roofline whether used at high or low level.

The tortured path through the 4mm louvred grill and internal weathering geometry is designed to maintain a 10k mm<sup>2</sup> of airflow whilst channelling any water ingress out of the vent and on to the roof covering.

<b>Weight</b>	1.1kg
<b>Box Qty</b>	4 (4.6kg per box)
<b>Materials - Top Base</b>	PVC Polypropylene
<b>Colours</b>	Terracotta, Grey, Brown & Antique Red
<b>Manufacturing</b>	Injection Moulded
<b>Free Airflow</b>	10K mm <sup>2</sup> per unit

**Features**

- In-line and discreet low profile design.
- 4mm louvred flyscreen grill.
- Integral sidelock clip to ensure secure fit.
- Range of profiles and colours available.
- Profiles suit all top tile manufacturers.
- Fully independently wind tunnel tested.
- Base outlet feeds directly into roof space.
- Adaptor available for mechanical extraction.
- Suitable for use down to a 20° roof pitch.

**References**

BSI: BS 5250:2002 Control of Condensation in Building  
 BSI: BS 5534:2003 Code of Practice for Slate and Tiling  
 BSI: BS 490:2004 Concrete tiles and fittings for roof covering  
 BRE: prEN 15601  
 Building Regulations 2010  
 NHBC: Good Craftsmanship Guides

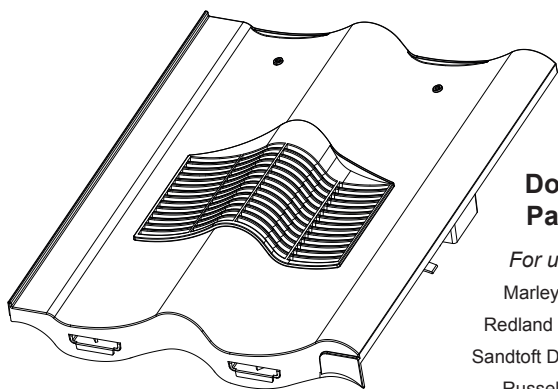

**Double Pantile**

For use with:  
 Marley Mendip\*  
 Redland Grovebury\*  
 Sandtoft Double Pantile  
 Russell Pennine

\* Profile requires vent modification.

MANTHORPE BUILDING PRODUCTS LTD  
 MANTHORPE HOUSE  
 BRITAIN DRIVE  
 CODNOR GATE BUSINESS PARK  
 RIPLEY  
 DERBYSHIRE DE5 3ND

TEL: 01773 303 000  
 FAX: 01773 303 300  
 EMAIL: customercare@manthorpebp.co.uk  
 WEB  
 www.manthorpebp.co.uk

DRN B.H. Date 19.06.19  
 The company maintains a policy of continuous development of its product range and reserves the right to amend the specification without notice.

DRG No  
**MBP 8295**

Issue  
**B**