

Tile Access Panel

Code: **GLTAP-500**

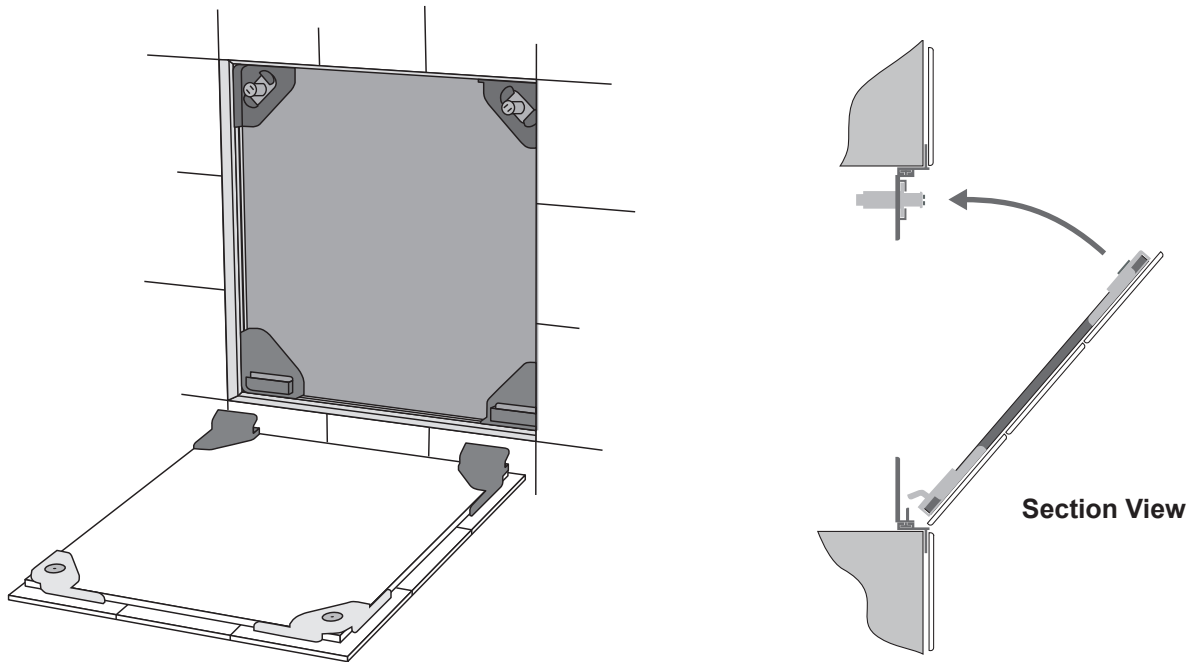

Description

The Manthorpe Tile Access Panel is a versatile kit of parts that can be quickly assembled to form a cloaked access panel within a tiled wall. The panel is completely flexible and can be used with most size or thickness of tiles to form an access panel of any varying dimensions.

**Variable Dimensions: Minimum 150mm x 150mm
Maximum 465mm x 465mm**

The Access Panel can be installed into all existing wall panel materials whether it is plasterboard or tile backer board of any thickness, the finished Manthorpe Tile Access Panel will always fit flush with the surrounding tiles.

The Access Panel is supplied ready, with a 6mm thick fibre cement tile backer board and a full set of fitting instructions. The fibre cement board is an ideal backing board for receiving all types of tile adhesive or grout with minimal warp after tiling.

Once complete the Manthorpe Tile Access panel can be accessed effortlessly by pressing on the magnetic touch catches and then fully releasing the panel from its hinges.

Safety

Tile Backing Board	To limit respirable silica exposure, when handling or cutting backing board wear a dust mask or respirator (eg P2) in accordance with applicable government regulations.
---------------------------	--

MANTHORPE BUILDING PRODUCTS LTD
MANTHORPE HOUSE
BRITAIN DRIVE
CODNOR GATE BUSINESS PARK
RIPLEY
DERBYSHIRE
DE53ND

TEL: 01773 303 000
FAX: 01773 303 300
EMAIL: customercare@manthorpebp.co.uk
WEB: www.manthorpebp.co.uk

DRN P.S

DATE 25.06.19

DRG No

ISSUE

The company maintains a policy of continuous development of its product range and reserves the right to amend the specification without notice.

MBP 8235
(PAGE 1 OF 2)

C

Tile Access Panel

Code: **GLTAP-500**

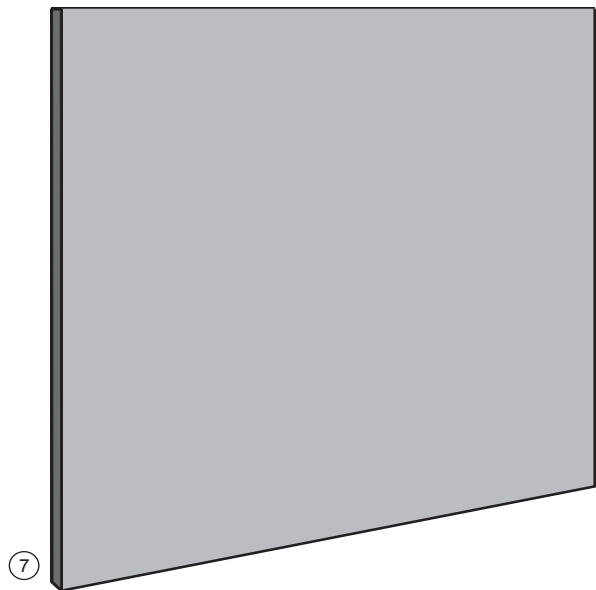
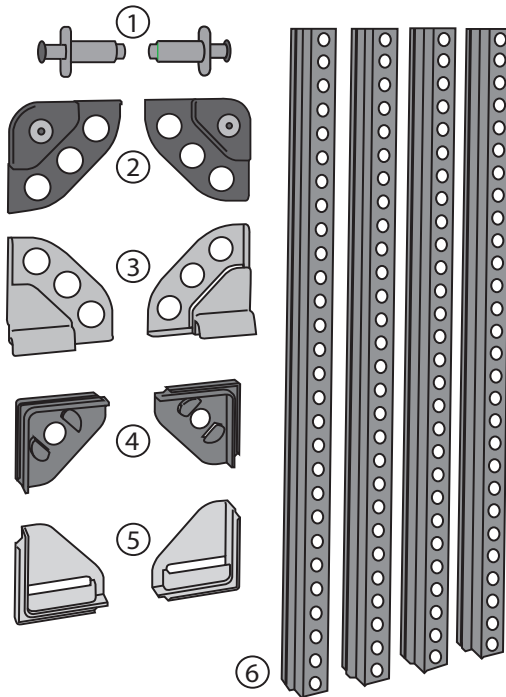

Kit List

No	Part	Qty	Material
1	Magnetic Touch Latches	2	White High Impact Polystyrene
2	Clip-on Corners with Contact Plates	2	White High Impact Polystyrene / Zinc Coated Steel
3	Clip-on Corner Hinges	2	White High Impact Polystyrene
4	Corner Magnet Supports	2	White High Impact Polystyrene
5	Corner Hinge Supports	2	White High Impact Polystyrene
6	Lengths of Frame Beading	1	White uPVC
7	Tile Backing Board	1	Fibre Cement Board

Specification

Packing Details	Packed individually or in boxes of 5
Weight	1 Unit = 2.8 Kg per box 5 Units = 13.4 Kg per box
Manufacturing Process	Injection Moulded / Plastic Extrusion

MANTHORPE BUILDING PRODUCTS LTD
 MANTHORPE HOUSE
 BRITAIN DRIVE
 CODNOR GATE BUSINESS PARK
 RIPLEY
 DERBYSHIRE
 DE53ND

TEL: 01773 303 000
 FAX: 01773 303 300
 EMAIL: customercare@manthorpebp.co.uk
 WEB: www.manthorpebp.co.uk

DRN P.S

DATE 25.06.19

DRG No

ISSUE

The company maintains a policy of continuous development of its product range and reserves the right to amend the specification without notice.

MBP 8235
 (PAGE 2 OF 2)

C